



136 North Monroe Street  
Waterloo, WI 53594  
Phone: (920) 478-3025  
Fax: (920) 478-2021  
[www.waterloowi.us](http://www.waterloowi.us)

**CITY OF WATERLOO COUNCIL AGENDA**  
**COUNCIL CHAMBER OF THE MUNICIPAL BUILDING – 136 N. MONROE STREET**  
**Thursday, December 16, 2021 – 7:00 p.m.**  
**Participate Remotely Or In-Person**

Remote Meeting Information

Join Zoom Meeting: <https://us02web.zoom.us/j/83968749069?pwd=MmxMWG16Wk9LYjR5dnpGM2tieTFmUT09>  
Dial-In By Phone : +1 312 626 6799 US  
Meeting ID: 839 6874 9069 Passcode: 685711

Pursuant to Section 19.84 Wisconsin Statutes, notice is hereby given to the public and news media, that a public meeting will be held to consider the following:

1. CALL TO ORDER, PLEDGE OF ALLEGIANCE & ROLL CALL
2. MEETING MINUTES APPROVAL: December 2, 2021
3. CITIZEN INPUT / PUBLIC COMMENT
4. NOTIFICATION OF DENIAL OF CITIZEN REQUEST OF AGENDA ITEM PER §30-4(L) MUNICIPAL CODE
5. MEETING SUMMARIES (since last Council meeting)
  - a. 12-07 Water & Light Commission
  - b. 12-16 Finance, Insurance & Personnel Committee
6. CONSENT AGENDA ITEMS
  - a. November Reports Of City Officials & Contract Service Providers
    - i. Parks
    - ii. Fire & Emergency Medical Services
    - iii. Building Inspections
    - iv. Public Works
    - v. Police
    - vi. Library Board
    - vii. Water & Light Utility Commission
    - viii. Watertown Human Society
7. RECOMMENDATIONS OF BOARDS, COMMITTEES AND COMMISSIONS
  - a. Finance, Insurance & Personnel Committee
    - i. 2022 Insurance Renewals - League Of Municipalities Mutual Insurance Company, Invited Paul Lessila With R & R Insurance
    - ii. Authorizing An Expenditure Not To Exceed \$108,000 In Waterloo Area Community Foundation Funding And Park Board Trustees Funding For Playground Equipment At Multiple Park Locations
    - iii. Resolution #2021-49 Amending The 2021 Budget – Amendment #2 (handout at time of meeting)
8. NEW BUSINESS
  - a. Property Owner Request For Public Sidewalk Closure During Winter Months, 970 Industrial Lane
9. FUTURE AGENDA ITEMS AND ANNOUNCEMENTS
  - a. Resolution #2021-35 Updating The City Of Waterloo Fee Schedule
10. ADJOURNMENT

Mo Hansen  
Clerk/Treasurer

Posted & Emailed: 12/14/2021

PLEASE NOTE: It is possible that members of and possibly a quorum of members of other governmental bodies of the municipality may be in attendance at the above meeting(s) to gather information. No action will be taken by any governmental body other than that specifically noticed. Also, upon reasonable notice, efforts will be made to accommodate the needs of disabled individuals through appropriate aids and services. For additional information or to request such services please contact the clerk's office at the above location



**CITY OF WATERLOO COMMON COUNCIL -- MEETING MINUTES: December 2, 2021**

[a digital recording of this meeting also serves as the official record]

1. CALL TO ORDER, PLEDGE OF ALLEGIANCE & ROLL CALL. Mayor Quimby called the meeting to order at 7:03 p.m. Alderpersons present: Cummings, Rhynes; Kuhl, Griffin, Thomas, Weihert and Petts. Absent: none. Others attending remotely or in-person: Everett Butzine; Ryan Spoehr with the Courier; Library Director Kelli Mountford; Public Works Director Chad Yerges; Utility Superintendent Barry Sorenson; WLOO videographers; and Clerk/Treasurer Hansen. The pledge of allegiance was recited.
2. MEETING MINUTES APPROVAL: November 18, 2021. MOTION: [Kuhl/Griffin] to approve minutes as presented. VOICE VOTE: Motion carried with Petts abstaining. Motion carried.
3. CITIZEN INPUT / PUBLIC COMMENT
4. NOTIFICATION OF PUBLISHED NOTICES - Municipal Spring Elections – Spring Election, April 5, 2022. Noted.
5. MEETING SUMMARIES. Brief meeting summaries provided.
  - a. 11/22 Community Development Authority
  - b. 11/22 Fire / Emergency Medical General Meeting
  - c. 11/23 Library Board
  - d. 12/01 Parks Commission
  - e. 12/02 Public Safety & Health Committee
  - f. 12/02 Public Works & Property Committee
6. RECOMMENDATIONS OF BOARDS, COMMITTEES AND COMMISSIONS
  - a. Community Development Authority
    - i. Resolution #2021-48 Rescinding An Economic Development Services Agreement With Baker Tilly And Recommending Entering Into An Economic Development Services Agreement With NMC Non-metro Connections. MOTION: [Weihert/Petts] to approve the motion as presented. VOICE VOTE: Motion carried.
7. NEW BUSINESS
  - a. Ordinance #2021-09 Amending § 350-7: Parking Restrictions Of The Municipal Code Relating To Rental Parking In Municipal Lots. MOTION: [Thomas/Cummings] to approve the ordinance. VOICE VOTE: Motion carried.
8. FUTURE AGENDA ITEMS AND ANNOUNCEMENTS
  - a. Resolution #2021-35 Updating The City Of Waterloo Fee Schedule. Noted.
9. ADJOURNMENT. MOTION: [Kuhl/Thomas] to adjourn. VOICE VOTE: Motion carried. Time: 7:15 p.m.



Attest:  
Mo Hansen, Clerk/Treasurer

## Mo Hansen

---

**From:** Jeni Quimby  
**Sent:** Tuesday, November 30, 2021 9:27 PM  
**To:** Mo Hansen; Eric Rhynes; Charles Kuhl; Mike Tschanz; Jeanette Petts; Rich Weihert; Ron Griffin (griffinrepair@gmail.com); Sara Cummings; Tim Thomas; Keri Sellnow (kesellnow@gmail.com)  
**Cc:** Chris Butschke; Mike Tschanz; Jeanne Ritter  
**Subject:** Re: Citizen Request For City Council Agenda Item / Notice Of Denial / 129 North Monroe Street / Sellnow Properties LLC

The reason for the council denial was meant to be included.

Based on the remarks Chris has made, permits have not been pulled & issues addressed. If an ordinance needs review, it would go to the planning commission 1st, which Chris is also a part of.

Keri if that is what you would like, the next meeting should be Tuesday the 23rd, or January depending on a quorum for the holidays.

Thanks,  
Jenifer Quimby, Mayor  
Sent from my U.S.Cellular©

---

**From:** Mo Hansen <mhansen@waterloowi.us>  
**Sent:** Tuesday, November 30, 2021, 3:17 PM  
**To:** Jeni Quimby; Eric Rhynes; Charles Kuhl; Mike Tschanz; Jeanette Petts; Rich Weihert; Ron Griffin (griffinrepair@gmail.com); Sara Cummings; Tim Thomas  
**Cc:** Chris Butschke; Mike Tschanz; Jeanne Ritter  
**Subject:** Citizen Request For City Council Agenda Item / Notice Of Denial / 129 North Monroe Street / Sellnow Properties LLC

FYI City Council Members:

Per section [30-4\(L\)](#) of the municipal code, this is notice that a Keri Sellnow 11/29/2021 request for an item to be added to the City Council agenda has been denied by the Mayor. To learn more about how items are placed on agendas, see [30-4\(L\)](#).

Mo Hansen | Clerk/Treasurer | [City of Waterloo](#) | 920.478.3025

---

**From:** Mo Hansen  
**Sent:** Tuesday, November 30, 2021 3:11 PM  
**To:** Keri Sellnow (kesellnow@gmail.com) <kesellnow@gmail.com>  
**Cc:** Jeni Quimby <mayor@waterloowi.us>; Jeanne Ritter <jritter@waterloowi.us>  
**Subject:** FW: 129 North Monroe Street / Sellnow Properties LLC

Keri,  
Mayor Quimby forwarded a verbal “no” reply to your request for a Council agenda item. This email serves as notification of her reply. Please see below to learn more about Section 30-4(L) of the municipal code and agenda items. Additionally, per 30-4(L) of the municipal code, I will inform the City Council of the Mayor’s reply.

This action does not prevent you from attending any public meeting and addressing the body on a topic of your choosing, under Citizen Input. It only means the request for an agenda action item, allowing for action by the body as you requested, has been turned down by the Mayor.

**From:** Mo Hansen  
**Sent:** Monday, November 29, 2021 8:50 AM  
**To:** Jeni Quimby <[mayor@waterloowi.us](mailto:mayor@waterloowi.us)>  
**Cc:** Mike Tschanz <[mtschanz@waterloowi.us](mailto:mtschanz@waterloowi.us)>; Chris Butschke <[cbutschke@safebuilt.com](mailto:cbutschke@safebuilt.com)>  
**Subject:** FW: 129 North Monroe Street / Sellnow Properties LLC

Mayor

Keri Sellnow has requested an item to be placed on the December 16<sup>th</sup> City Council agenda relating to her a Building Inspection non-compliance matter. Per [§ 30-4\(L\): Standing Rules](#) municipal code (pasted below...), the item may be on the agenda subject to your approval. Please advise on how you want to proceed. Thank you.

Mo Hansen | Clerk/Treasurer | [City of Waterloo](#) | 920.478.3025

[L.](#)

Council and committee agendas. Items shall be placed on the agenda of any Council or standing committee meeting if requested by: the Mayor, any Alderperson, the City Clerk/Treasurer or any department head. Items may be placed on the agenda of any Council or standing committee meeting if requested by any other person, subject to the approval of the Mayor and/or the Committee Chairperson. The Council shall receive notice of any denial of a request to place an item on the Council or a standing committee agenda. Requests to place items on the agenda should comply with the notice requirements of the Wisconsin Open Meetings Law (§ 19.84, Wis. Stats.) and the policies and procedures of the Clerk/Treasurer's office.

---

**From:** Keri Sellnow <[kesellnow@gmail.com](mailto:kesellnow@gmail.com)>  
**Sent:** Saturday, November 27, 2021 7:57 AM  
**To:** Chris Butschke <[CButschke@safebuilt.com](mailto:CButschke@safebuilt.com)>  
**Cc:** Mo Hansen <[mhansen@waterloowi.us](mailto:mhansen@waterloowi.us)>; Mike Tschanz <[mtschanz@waterloowi.us](mailto:mtschanz@waterloowi.us)>  
**Subject:** Re: 129 North Monroe Street / Sellnow Properties LLC

Hey guys, We did discuss an architectural drawn plan. This is the first anything was said about 3 rentals and the building needing to be sprinkled to my recollection.... I could be wrong. As far as a drawing showing building revisions...again...I will tell you we made cosmetic improvements. We did not move, open or create interior revisions to the building. We used existing plumbing and structure which was permitted in 1995 prior to opening the coffee shop. The tenant is going to leave in March or April. I will not make her leave before and then the property can sit empty. I'm tired of trying to make something work to the benefit of the community...hopefully someone will buy it and then they can work through the process you are requiring. We do not have the financial ability to pay a licensed architect the fee they will charge presently, if there is even one that will do it because it is more hassle for them than it is worth at this time. Ive had 1 say they are too busy and I dropped the ball after that. Mo, I would like to be put on the council agenda the middle of December regarding trying to change either the zoning ordinance or the requirements making it possible for others to be able to have a mixed use based on a percentage of the first floor square footage. Maybe that will eliminate someone else from dealing with this issue. Thanks for your attention to this.

On Tue, Nov 23, 2021, 11:14 AM Chris Butschke <[CButschke@safebuilt.com](mailto:CButschke@safebuilt.com)> wrote:

Hi Mo,

She met with me and we discussed what was required for compliance. She was to hire a design professional to submit a stamped plan to me for review. I have not received the plan.

Compliance would need to be: a stamped plan showing the commercial remodel alteration, permits being pulled for the remodel alteration, inspection for compliance.

the key is the stamped plans, this will tell me if the building as a whole is compliant. If she has three tenants( apartments) it needs to be sprinkled unless she meets exceptions per the design review.

Sorry but this was discussed with her in my office. I do not need to be in the building until the plans are submitted and reviewed and permits are pulled. Otherwise I can go in when the occupancy is changed and the alterations returned to prior floor plan?

Thanks,

Chris Butschke

Sent from my iPad

On Nov 23, 2021, at 8:55 AM, Mo Hansen <[mhansen@waterloowi.us](mailto:mhansen@waterloowi.us)> wrote:

Chris,

Thanks for your efforts on gaining code compliance for Waterloo properties.

Keri Sellnow called regarding her non-compliance notice at 129 North Monroe Street.

- Keri acknowledged receipt of the most recent non-compliance letter. She said receipt was delayed.
- She indicated an interest in converting the full first-floor to commercial as a means to comply.
  - She has a tenant currently renting on the first floor.
- She indicated she had invited you to inspect the property. I indicated you are not responsible for crafting a remedy.
- She said you had not been in the building, and the detail from the non-compliance notice may be unclear as to how she may comply.
  - She stated she believes she is in compliance.
- I said her situation is the only situation in Waterloo's downtown where a first floor property is split between a residential use and a commercial use.
- She inquired about the fine amount. I reviewed and read to her [§1-4: Violations and penalties from the municipal code](#).

Mo Hansen | Clerk/Treasurer | [City of Waterloo](#) | 920.478.3025

<image001.jpg>

<Sellnow Keri.vcf>



136 North Monroe Street  
Waterloo, WI 53594  
Phone: (920) 478-3025  
Fax: (920) 478-2021  
[www.waterloowi.us](http://www.waterloowi.us)

---

## **PARKS COORDINATOR REPORT**

**October 2021 – November 2021**

### **EVENTS AND HIGHLIGHTS**

- HOLIDAY OF LIGHTS
  - 12 contestants – Most ever!
- HOLIDAY PARADE – December 11, 2021
  - Still taking in Registrations
    - 13 – Registrations
- WINTERFEST – December 11 & 18
  - Vendor Fair
    - Cookie Contest
      - 0 – Registrations
    - Gingerbread Contest
      - 4 – Registrations
  - Community Party w/Santa
    - Chili Cookoff
      - 2 – Registrations
  - Sled Races
  - Snowman Contest
  - Winter Formal
    - 4 – Registrations
    - Lots of talk – changing registrations to include without food

### **ONGOING PROJECTS**

- LOWER PAVILION WORK
  - Sump Pump Installed
  - Plumbing Issues found
    - Toilet Flush Valves
    - Urinal Flush Valves
    - Replace Cast Iron Piping from Upstairs Women's Toilets
    - Proper Venting in Lower Pavilion Bar Area
- FENCE PROJECT
  - TBD – Waiting of Fencing Company
- BATHROOM RENOVATION
  - Estimate received from Krueger
- DUG-OUT/PRESS BOX RENOVATIONS
  - Waiting on fencing to be completed

- PLAYGROUND EQUIPMENT
  - On Agenda for tonight with a estimate from Lee Recreation

### **FINISHED PROJECTS**

- ROUNDHOUSE CONCRETE
- MAIN RED DOOR REPLACED ON CAROUSEL ENTRANCE/EXIT
- LIFT STATION
  - SCADA System Complete
- KITCHEN DOOR REPLACEMENT
- LOWER PAVILION SUMP PUMP

### **CAROUSEL**

- RED DOOR REPLACEMENT
  - Waiting on Door Company

### **PROJECTS FOR 2022**

- LOWER PARKING LOT PAVING
  - Paving area in front of concession stand over to the Carousel
- KITCHEN RENOVATION
  - Updating Kitchen for possible rentals
- AIR CONDITION UPDATES
  - New AC at Waterloo Regional Trailhead
  - Updating AC in Park Pavilion

### **DONATION CAMPAIGNS**

- WinterFest Formal Party
  - Raffles and Meal Ticket Fundraiser

### **GRANT OPPORTUNITIES**

- 203 EAST MADISON STREET PROJECT
  - DNR Grants
    - Denied
- GWHF
  - Grant received
    - \$100,000 – Putting Grant towards possible new playground equipment.



WATERLOO FIRE & RESCUE  
 900 INDUSTRIAL LANE  
 WATERLOO, WISCONSIN 53594



Department Activity Report – November  
 Call Report for the month of November

**EMS Calls:**

City of Waterloo	33
Township of Waterloo	2
Township of Portland	1
2 <sup>nd</sup> out Ambulance City of Waterloo	1
2 <sup>nd</sup> out Ambulance Mutual Aid for Watertown	1

**Total EMS 38**

**EMS & Fire Motor Vehicle Crash Calls:**

Township of Portland	1
----------------------	---

**Total MVC 1**

**Alarms:**

City of Waterloo	1
------------------	---

**Fire Calls:**

City of Waterloo	1
Township of Waterloo	1
Township of Shields	1
Mutual Aid for Fall River	1
Mutual Aid for Lake Mills	1
Mutual Aid for Watertown	1

**Hazardous Condition:**

City of Waterloo	2
------------------	---

**Weather Related Call:**

Waterloo Fire District	0
------------------------	---

**Service Calls:**

City of Waterloo	2
------------------	---

**Rescue Calls:**

City of Waterloo	0
------------------	---

**Total Fire 11**

**November Total 50**

**Up to Date Call Totals**

Fire (Structure, Wild land, Motor Vehicle)	52
Rescue/EMS: BLS ALS	349
Hazardous Conditions (No Fire)	17
False Alarm or Call	26
Motor Vehicle Crash	9
Service Calls	36
Rescue Calls	0
Weather Related Calls	1

**Up to Date Total 490**

**Fire Mutual Aid Given 32 Fire Mutual Aid Received 8**

**2<sup>nd</sup> Out Unit 11 EMS Mutual Aid Given 8 EMS Mutual Aid Received 5 Paramedic Intercept 11**

**Total Personnel Response: 2013 (for the month): 188**

Monthly Response Time (EMS Incidents) **237** (From 1<sup>st</sup> page to enroute times) average **6.0** min (for the month)

Minutes Spent Responding **116** (Enroute time to on scene time) average **2.9** min (for the month)

Monthly Response Time (FIRE Incidents) **67** (From 1<sup>st</sup> page to enroute times) average **6.0** min (for the month)

Minutes Spent Responding **81** (Enroute time to on scene time) average **7.3** min (for the month)





WATERLOO FIRE & RESCUE  
900 INDUSTRIAL LANE  
WATERLOO, WISCONSIN 53594



Wednesday December 1<sup>st</sup>, 2021

On Monday November 1<sup>st</sup>, 2021 we had our monthly Operators training. Training was on aerial operations. Operators have to judge the distance and where the tip of the ladder will end up. This training we have cones on top of our training center and one attached to the tip of the ladder. The operators have to place the cone on the ladder over the cone on the training center.

On Monday November 8<sup>th</sup>, 2021 we had our monthly EMS training. Training was back to the basics. The members were dispatched to a location where they had to figure out little details and relay them back to the instructor. This is to make sure that we cover all of our basic to make sure we get to the main problems.

On Monday November 15<sup>th</sup>, 2021 we had our monthly Fire training. Training was on packing hose and tool and equipment maintenance. Packing hose is a skill, if the hose is packed incorrectly when you deploy the hose it can delay getting water on the fire because it can be one knot after another. So, the members went over how to pack the 2 ½ inch hose. The members went through both engines cleaned and made sure all tools were in good condition and that they start easily.

On Monday November 29<sup>th</sup>, 2021 we had our quarterly combination training. Training was on RTF (Rescue Task Force). RTF is teams of two where there has been a multicausality situation. Our members have to don the proper ballistic gear and work with law enforcement. With the help of the Waterloo Police Department for the equipment they allowed us to use and the help of St. John's school for allowing us to use the building. Our members trained on tactical entrance, triage and stop the bleed, movement of victims to a casualty collection point and making sure all patients were accounted for and which hospital they were transported to.

This spring Garry Whitebird and Nick Thomas had completed their EMT course and are now going through their AEMT course. Colton Butzine has completed the Emergency service instructor training.

Sincerely,

Chief Wesley Benisch  
Waterloo Fire Department  
900 Industrial Ln.  
Waterloo WI 53594  
920-478-2535  
[chief@waterloowi.us](mailto:chief@waterloowi.us)

(920) 478-2535

FAX (920) 478-9597

[chief@waterloowi.us](mailto:chief@waterloowi.us)





**Invoice**

**Invoice Number:** 0082312-IN  
**Invoice Date:** 11/30/21  
**Terms:** Net 30 Days  
**Due Date:** 12/30/21

**Salesperson:** 0000  
**Customer Number:** 11-WATERL2  
**Customer P.O.:**

CITY OF WATERLOO  
 136 N MONROE STREET  
 Waterloo, WI 53594-1198

**WI - Invoicing**

Fee Type	Amount Paid	Paid Date	% Due to 3rd Party	Amount Due to 3rd Party
<b>Permit # 21WTRC-0181-21-11PLOS</b>				<b>Plumbing Permit</b>
New Home OS Sewer & Water L	60.00	11/02/21	60.00	36.00
<b>21WTRC-0181-21-11PLOS Subtotal</b>				<b>36.00</b>
<b>Permit # 21WTRC-0182-21-11BE</b>				<b>Accessory Structure (Residenti</b>
Electrical- New Building/Additon	45.00	11/04/21	60.00	27.00
Accessory Structure- Residentia	60.00	11/04/21	60.00	36.00
<b>21WTRC-0182-21-11BE Subtotal</b>				<b>63.00</b>
<b>Permit # 21WTRC-0183-21-11PLOS</b>				<b>Plumbing Permit</b>
New Home OS Sewer & Water L	60.00	11/04/21	60.00	36.00
<b>21WTRC-0183-21-11PLOS Subtotal</b>				<b>36.00</b>
<b>Permit # 21WTRC-0184-21-11E</b>				<b>Electrical Permit</b>
Electrical- Replacement & Misc.	50.00	11/08/21	60.00	30.00
<b>21WTRC-0184-21-11E Subtotal</b>				<b>30.00</b>
<b>Permit # 21WTRC-0185-21-11B</b>				<b>Fence</b>
Other Fee- Residential	50.00	11/08/21	60.00	30.00
<b>21WTRC-0185-21-11B Subtotal</b>				<b>30.00</b>
<b>Permit # 21WTRC-0186-21-11E</b>				<b>Electrical Permit</b>
Electrical- Replacement & Misc.	50.00	11/16/21	60.00	30.00
<b>21WTRC-0186-21-11E Subtotal</b>				<b>30.00</b>
<b>Permit # 21WTRC-0187-21-11H</b>				<b>HVAC Permit</b>
HVAC- Replacement & Misc. lte	110.00	11/16/21	60.00	66.00
<b>21WTRC-0187-21-11H Subtotal</b>				<b>66.00</b>
<b>Permit # 21WTRC-0188-21-11BE</b>				<b>Accessory Structure (Residenti</b>
Electrical- New Building/Additon	69.20	11/22/21	60.00	41.52
Accessory Structure- Residentia	92.40	11/22/21	60.00	55.44
<b>21WTRC-0188-21-11BE Subtotal</b>				<b>96.96</b>

**WI - Invoicing**

Please remit to: SAFEbuilt, LLC Lockbox# 88135  
 P.O. Box 88135, Chicago, IL, 60680-1135

Net Invoice:	387.96
Freight:	0.00
Sales Tax:	0.00
<b>Invoice Total:</b>	<b>387.96</b>



Fee Type	Amount Paid	Paid Date	% Due to 3rd Party	Amount Due to 3rd Party
<b>Summary Fee Type</b>				
<b>ItemCode</b>	<b>Description</b>			<b>Amount</b>
/PERMITS	Building Permits			387.96
<b>Total</b>				<b>387.96</b>

Please remit to: SAFEbuilt, LLC Lockbox# 88135  
P.O. Box 88135, Chicago, IL, 60680-1135

Net Invoice:	387.96
Freight:	0.00
Sales Tax:	0.00
<b>Invoice Total:</b>	<b>387.96</b>

Machinery and Equipment Maintenance  
2020 DPW

NOVEMBER

Equipment		Mileage			TTI Fuel	GPH
		Start	End	Total		
End loader	544	3998	4046	48	0	#DIV/0!
John Deere Tractor	2555	4778	4804	26	17.51	1.48
Wood Chipper	Chipper	2942	2949	7	13.073	0.54
John Deere Lawn Tractor	1025R	152	152	0	22.196	0.27
John Deere	X750	1697	1701	4	22.196	0.27
John Deere	X750-1	1462	1464	2	22.196	0.27
Wacker Roller	roller	420	421	1	0	#DIV/0!
2010 International Truck	#1	23622	23683	61	16.27	3.75
2020 International Truck	#2	4661	4668	7	0	#DIV/0!
	#3			0	0	#DIV/0!
2017 Chevrolet Truck	#4	46913	47310	397	52.456	7.57
2018 Frieghtliner Truck	#5	10631	10796	165	45.828	3.60
2006 Elgin Pelican Street Sweeper	sweeper	43347	43347	0	0	#DIV/0!
2011 Ford F-550 Truck	#6	40710	40954	244	46.616	5.23
2015 Frieghtliner Trucki	#7	13386	13886	500	0	#DIV/0!
Bobcat		664	679	15	0	#DIV/0!

# MONTHLY TIME REPORT

2021

## NOVEMBER

JOB	DPW	Chad	Ryan	Chris	Travis
Police Adm		0	0	0	0
Fire Dept		0	0	0	0
Mach/Equip		7	24	14	8
Garage/Shed		23	4	13.5	15
Meeting/Seminars		17.5	0	0	0
Street Repair/Maintenance		15	15	0	12
Street Cleaning		0	0	0	0
Snow & Ice	Reg Hrs	0	3	0	2
	OT Hrs	0	0	0	0
Storm Sewer		6	0	0	0
Traffic Control		0	2	0	2
Bridges/Culvers		0	0	0	0
Tree/Brush		0	7	13	6
Refuse Collection		43	78	56	69
Sanitary Sewer		0	0	0	0
Insect Control		0	0	0	0
Animal Control		0	0	0	0
Cemetary		0	1	1	0
Library		0	0	0	0
Firemans Park		19	4	2	0
Other Parks		5	4	2	2
Trail Head		1	1	0	1
Celeb/Enter		0	0	0	0
Weed Control		0	0	0	0
Vac/Holiday/SL		40	32	74.5	59

# WATERLOO POLICE DEPARTMENT OFFICER'S DAILY -NOVEMBER

Patrol:	248.25	Office:	97.50
Investigative:	30.50	Special:	0
Radar:	43.75	School/Training:	0
Court:	0	On Call:	0

Total Hours Worked: 420.00

COMPLAINTS	
Family:	1
Off Road Vehicles:	0
Vandalism:	0
Minor Theft - \$500:	2
Major Theft + \$500:	1
Burglary:	0
Doors Found Open:	4
Animal Case:	3
Late Bar Closings:	0
Alarms:	0
Loud Music/Parties:	2
Tavern Complaints:	0
Prowler Complaints:	1
Battery to Person:	0
Domestic Abuse:	0
Sexual Assault:	0
Runaways:	0
Worthless Checks:	0
All Other Complaints:	28
<b>TOTAL COMPLAINTS:</b>	<b>42</b>

ACCIDENTS	
More than \$1,000:	1
Less than \$1,000:	0
Pedestrian Accidents:	0
Bicycle Accidents:	0
Number Injured:	2
Number Killed:	0
<b>TOTAL ACCIDENTS:</b>	<b>1</b>

ASSISTS	
Assist Jefferson County:	0
Assist Dodge County:	0
Assist Dane County:	0
Assist Marshall PD:	0
Assist Fire/Rescue:	14
Assist Other Agencies:	3
Assist Public:	34
Assist With Escort:	2
Assist All Others:	5
<b>TOTAL ASSISTS:</b>	<b>58</b>

MISCELLANEOUS	
Personal Contacts:	34
Investigations/Follow-up:	3
Traffic Control:	63
Radar Operations:	0
Special Assignment:	0
Speech/Presentation:	0
Serve Papers:	0
Other Miscellaneous:	0
<b>TOTAL:</b>	<b>100</b>

INQUIRIES/CHECKS	
Registration Checks:	557
D.L. Checks:	169
NCIC/CIB/VIN Checks:	0
Check Welfare:	5
<b>TOTAL INQUIRIES:</b>	<b>731</b>

	Warnings	Arrests
Speeding:	7	0
Too Fast For Conditions:	0	0
Inattentive Driving:	0	0
Failure to Yield:	0	0
Stop Sign Violation:	1	0
Illegal Passing:	2	6
No Driver's License:	0	3
Illegal Parking:	2	6
Left of Highway:	0	0
Drunk Driving:	0	0
Unregistered Vehicle:	2	1
Driving While Sus/Rev:	0	0
Hit And Run:	0	0
Off Road Vehicle:	0	0
Power Display:	0	0
Equipment:	8	1
Illegal "U" Turn:	0	2
Following Too Close:	0	0
Seatbelt Violation:	0	0
<b>ALL OTHER TRAFFIC:</b>	<b>4</b>	<b>5</b>

Disorderly Conduct:	0	0
Underage Alcohol:	0	0
Warrants:	0	0
Theft:	0	0
Trespassing:	0	0
Burglary/Break & Enter:	0	0
Vandalism:	0	0
<b>ALL OTHER MIS/CRIM:</b>	<b>0</b>	<b>0</b>
<b>TOTALS:</b>	<b>0</b>	<b>0</b>

Monthly Incident Comparison Report

Report Criteria:

Current Month: 11/2021

Category	Description	Current Month	Prior Month	Year To Date	Same Mo. Last Year	Last Year
No Category	Blank Description	0	0	2	1	2
	<b>Total for No Category:</b>	<b>0</b>	<b>0</b>	<b>2</b>	<b>1</b>	<b>2</b>
ASSIST	Assist Business	0	0	0	0	1
	Assist Citizen	5	3	29	3	21
	Assist Dane County Sheriff	0	0	2	1	4
	Assist Dodge County Sheriff	2	1	13	2	12
	Assist Jefferson County Sheriff	0	1	7	0	1
	Assist Marshall PD	1	0	17	3	18
	Assist Probabtion/Parole	0	0	0	0	6
	Assist Public Works	0	1	1	0	0

## Monthly Incident Comparison Report

## Report Criteria:

Current Month: 11/2021

Category	Description	Current Month	Prior Month	Year To Date	Same Mo. Last Year	Last Year
ASSIST						
	Assist Social Services	5	3	15	0	12
	Assist Watertown PD	0	0	2	0	1
	Assist/School District	0	0	0	0	0
	Civil Dispute	0	0	2	0	0
	Custody for Other Department	0	0	4	0	2
	EMS Calls	0	1	1	0	3
	Fire Calls	0	0	1	0	0
	Neighbor Problems	0	0	1	0	1
	Other Mutual Aid Assists	0	0	3	0	2
	Probation/Parole Check Ins	1	0	1	0	3
	<b>Total for ASSIST:</b>	<b>14</b>	<b>10</b>	<b>99</b>	<b>9</b>	<b>87</b>
CRIMINAL						
	Abuse of Elderly/Vulnerable	0	0	0	0	0
	Bail Jumping/Escapes	0	0	1	0	1
	Battery to Police Officer/Fireman	0	0	1	0	0
	Burglary - Attempted Residential	1	0	3	1	1
	Burglary - Residential/Forced	0	0	1	0	0
	Burglary - Residential/No Force	0	0	1	0	3
	Computer Crimes	0	0	1	0	1
	Criminal Damage To Property/vandalism	0	0	6	1	12
	Disorderly Conduct - All Other	0	2	8	1	16
	Disorderly Conduct - Fight, Disturbance	0	1	4	0	5
	Domestic Disturbance	0	1	11	0	18
	Domestic Offense - Child Abuse/Neglect	0	0	1	0	0
	Domestic Offense - Spousal Abuse/Fights	0	0	1	0	5
	Drug Investigations	0	2	3	0	8
	Drug Paraphernalia Possession	0	0	3	0	0
	Drug Possession	0	0	4	0	4
	Endanger Safety/Reckless Behavior	0	0	0	0	1
	Fraud	2	0	7	0	15
	Harass/Intimidate Victim or Witness	0	0	0	0	2
	Harassment - Harassing Telephone Calls	0	0	3	0	4
	Harassment - Stalking	0	0	1	0	0
	Harassment - Threats	1	0	4	0	5
	Indecent Language/Conduct	0	0	1	0	0
	Interfere with Child Custody	0	1	1	0	1

Monthly Incident Comparison Report

Report Criteria:

Current Month: 11/2021

Category	Description	Current Month	Prior Month	Year To Date	Same Mo. Last Year	Last Year
CRIMINAL						
	Operate Vehicle Without Owner's Consent	0	1	1	0	5
	Other Sex Offenses	0	2	6	1	5
	Probation/Parole Violation	0	0	1	0	1
	Robbery - Armed	0	0	1	0	0
	Simple Battery	0	0	4	0	0
	Suicide - Attempts/Threats	1	0	1	0	0
	Theft - All Other	1	2	18	1	13
	Theft - Bicycles	0	1	1	0	0
	Theft - From Building	1	0	2	2	4
	Theft - From a Motor Vehicle	0	0	5	1	7
	Theft - Motor Vehicle Parts/Accessories	0	0	6	1	2
	Theft - Retail/Shoplifting	1	0	4	1	8
	Theft of Library Materials	0	0	1	0	0
	Trespassing	0	0	0	1	1
	Violation of Court/Restraining Order	0	0	0	0	1
	Worthless Checks - Less Than \$1000	0	0	0	0	1
	<b>Total for CRIMINAL:</b>	<b>8</b>	<b>13</b>	<b>117</b>	<b>11</b>	<b>150</b>
ORDINANCE						
	Abandoned Property/Vehicle Violation	0	2	2	0	2
	All-Terrain Vehicle Violation	0	0	3	0	2
	Animal Bite	1	1	9	0	6
	Animal Licensing/Shots/Etc.	0	0	0	0	1
	Animal Noise Complaint	0	0	1	0	0
	Animal Running at Large	1	0	2	0	1
	Curfew	0	0	0	0	2
	Disturbance	0	1	10	0	2
	Fireworks Violation	0	0	2	0	0
	Harassment	0	0	1	0	0
	Illegal Dumping	0	0	0	0	1
	Littering Violation	0	1	2	0	0
	Loitering	0	0	0	0	1
	Municipal Code Violation	0	0	1	0	0
	Possession of Tobacco by Minor	1	3	8	0	0
	Public Nuisance Violations	1	0	1	0	1
	Truancy	0	0	0	0	2
	Under Age Drinking - Adult (18-21)	0	1	4	0	0
	Under Age Drinking - Minor (Under 18)	0	0	0	0	1
	<b>Total for ORDINANCE:</b>	<b>4</b>	<b>9</b>	<b>46</b>	<b>0</b>	<b>22</b>
Other						
	Investigation/Take Report	0	0	3	0	1



Monthly Incident Comparison Report

Report Criteria:

Current Month: 11/2021

---

Category	Description	Current Month	Prior Month	Year To Date	Same Mo. Last Year	Last Year
Other	Other Animal Calls - Dead, Etc.	0	0	4	0	4

Monthly Incident Comparison Report

Report Criteria:

Current Month: 11/2021

Category	Description	Current Month	Prior Month	Year To Date	Same Mo. Last Year	Last Year
Other	Receive Information	0	0	14	1	11
	<b>Total for Other:</b>	<b>0</b>	<b>0</b>	<b>21</b>	<b>1</b>	<b>16</b>
SERVICE						
	911 Disconnect (Hang-Up)	0	0	0	0	1
	Death Investigation	1	1	7	0	4
	Emergency Detention/Detoxification	0	0	0	0	4
	Found Items/Property	0	0	2	1	4
	Lost Items/Property	0	0	1	0	0
	Missing Adult	0	0	1	0	0
	Missing Juvenile	0	0	3	1	1
	Other Service	0	0	2	0	1
	Protective Custody/Placement	0	0	1	0	0
	Runaway Juvenile	0	0	0	0	2
	Suspicious Person/Activity, Prowler	0	0	3	1	7
	Transport	1	0	1	0	0
	Uncontrollable Juvenile	0	0	1	1	6
	Warrant Pickup - Other Agency	1	2	5	0	2
	Warrant Pickup - Waterloo	0	0	1	0	2
	Welfare Check	0	2	13	1	14
	<b>Total for SERVICE:</b>	<b>3</b>	<b>5</b>	<b>41</b>	<b>5</b>	<b>48</b>
TRAFFIC						
	Disobey Sign/Marker	0	0	1	0	1
	Driver's License Violations (Ex OAS/OAR)	1	3	10	1	17
	Driving Complaint	0	0	1	0	1
	Eluding Police Officer	0	0	2	0	1
	Illegal Turns	1	1	3	0	2
	Inattentive Driving	0	0	1	0	0
	License/Permit Violation	1	0	3	1	1
	Miscellaneous Rules Violation	0	0	1	0	0
	Motor Vehicle Carrier Violation	0	0	0	0	0
	Motor Vehicle Insurance Violation	1	1	16	0	15
	Motorcycle Violation	0	0	1	0	0
	OAS/OAR/Other License Violations	6	3	48	5	20
	Open Intoxicants - Driver	0	0	0	0	1
	Operate Motor Vehicle While Intoxicated	0	3	12	1	12
	Other Traffic Violations	0	0	12	0	2
	Parking Violation	0	0	0	0	18
	Registration/Title Violation	1	1	11	0	6
	Required Stop Violation - RR, Etc.	0	0	1	0	0
	Seatbelt Violation	0	0	2	0	0

Monthly Incident Comparison Report

Report Criteria:

Current Month: 11/2021

Category	Description	Current Month	Prior Month	Year To Date	Same Mo. Last Year	Last Year
TRAFFIC						
	Speeding - School Zone	0	0	1	0	1
	Speeding Violation	1	1	37	4	36
	Stop Sign/Signal Violation	0	4	15	1	6
	Tow Vehicle	0	0	1	0	1
	Traffic Accident - Hit and Run (Damage)	2	2	6	0	6
	Traffic Accident - Hit and Run (Injury)	0	0	1	0	0
	Traffic Accident - Non-Reportable	1	0	5	0	8
	Traffic Accident - Personal Injury	1	0	6	0	1
	Traffic Accident - Property Damage	2	1	18	2	20
	Traffic Obstruction/Debris on Highway	0	0	0	0	1
	Vehicle Equipment Violation - Lights	0	0	3	0	2
	Vehicle Equipment Violation - Other	0	0	0	0	3
	Warning - 5 Day Equipment Violation	0	0	2	0	0
	<b>Total for TRAFFIC:</b>	<b>18</b>	<b>20</b>	<b>220</b>	<b>15</b>	<b>182</b>
	<b>Grand Totals:</b>	<b>47</b>	<b>57</b>	<b>546</b>	<b>42</b>	<b>507</b>

Court Calendar Report

Report Criteria:

Start Date	End Date	Officer	Court Type
11/01/2021	11/30/2021	ALL	JEFFERSON CO CIRCUIT CT

Court Date	Name	Ticket	Officer/Court Type
11/01/21 9:30 AM	HERNANDEZ VITAL,EDUARDO,JESUS 506 BOWLAVARD AVE BELLEVILLE WI, 53508	DOB: 06/16/88 No: T-BF358972-5 Age: 33 Issued: 10/10/21 Inc #: 21-000459	CULLEN,NATHANIEL,J JEFFERSON CO CIRCUIT CT

Charge	Description	Fine	Collected
346.63(1)(A)	OWI (1ST W/PASSENGER < 16 YRS OLD)	\$500.00	\$0.00

11/01/21 9:30 AM	HERNANDEZ VITAL,EDUARDO,JESUS 506 BOWLAVARD AVE BELLEVILLE WI, 53508	DOB: 06/16/88 No: T-BF358973-6 Age: 33 Issued: 10/10/21 Inc #: 21-000459	CULLEN,NATHANIEL,J JEFFERSON CO CIRCUIT CT
---------------------	--	--	---

Charge	Description	Fine	Collected
346.63(1)(B)	OPERATING W/PAC-PASSENGER <16 YRS (1ST)	\$500.00	\$0.00

11/15/21 9:30 AM	TUSCHEN,TIMOTHY,M 134 E MADISON ST APT 1 WATERLOO WI, 53594	DOB: 11/12/85 No: T-BF358558-4 Age: 35 Issued: 10/11/21 Inc #: 21-000461	BURNS,RANDY JEFFERSON CO CIRCUIT CT
---------------------	---	--	--

Charge	Description	Fine	Collected
346.63(1)(A)	OPERATING WHILE UNDER THE INFLUENCE(3RD)	\$850.00	\$0.00

11/15/21 9:30 AM	TUSCHEN,TIMOTHY,M 134 E MADISON ST APT 1 WATERLOO WI, 53594	DOB: 11/12/85 No: T-BF358559-5 Age: 35 Issued: 10/11/21 Inc #: 21-000461	BURNS,RANDY JEFFERSON CO CIRCUIT CT
---------------------	---	--	--

Charge	Description	Fine	Collected
346.63(1)(B)	OPERATING W/PAC (3RD)	\$850.00	\$0.00

11/16/21 10:45 AM	[REDACTED] [REDACTED] [REDACTED]	[REDACTED] [REDACTED] [REDACTED]	BOLLIG,RANDY,P JEFFERSON CO CIRCUIT CT
----------------------	--	--	---

Charge	Description	Fine	Collected
165-2B(3)	UNDERAGE POSSESSION OF TOBACCO PRODUCTS	\$45.00	\$0.00

11/16/21 11:00 AM	HERNANDEZ VITAL,EDUARDO,JESUS 506 BOWLAVARD AVE BELLEVILLE WI, 53508	DOB: 06/16/88 No: T-BF358974-0 Age: 33 Issued: 10/10/21 Inc #: 21-000459	CULLEN,NATHANIEL,J JEFFERSON CO CIRCUIT CT
----------------------	--	--	---

Charge	Description	Fine	Collected
346.46(1)	FAIL/STOP AT STOP SIGN	\$175.30	\$0.00

11/16/21 11:00 AM	HERRERA,VICTORIA 151 1/2 W MADISON ST 2 WATERLOO WI, 53594	DOB: 08/16/92 No: T-BF358556-2 Age: 29 Issued: 10/03/21	WARNER,DAVID,N JEFFERSON CO CIRCUIT CT
----------------------	--	--	---

Charge	Description	Fine	Collected
344.62(1)		\$200.50	\$0.00

Court Calendar Report

Report Criteria:

Start Date	End Date	Officer	Court Type
11/01/2021	11/30/2021	ALL	JEFFERSON CO CIRCUIT CT

Court Date	Name	Ticket	Officer/Court Type
11/16/21	JILES,EARNEST,RAY K, JR	DOB: 10/31/01 No: T-BH526715-0	COFFREN,JARED
11:00 AM	335 CRESTVIEW DR WATERLOO WI, 53594	Age: 19 Issued: 10/13/21 Inc #: 21-000464	JEFFERSON CO CIRCUIT CT
Charge	Description	Fine	Collected
346.18(3)	FAIL/YIELD RIGHT/WAY FROM STOP SIGN	\$175.30	\$0.00

11/16/21	KRATOCHWILL,DANIEL,F	DOB: 12/23/57 No: T-BF358981-0	WARNER,DAVID,N
11:00 AM	624 KNOWLTON STREET APT #3 WATERLOO WI, 53594	Age: 63 Issued: 10/16/21 Inc #: 21-000474	JEFFERSON CO CIRCUIT CT
Charge	Description	Fine	Collected
346.46(1)	FAIL/STOP AT STOP SIGN	\$175.30	\$0.00

11/16/21	KRATOCHWILL,DANIEL,F	DOB: 12/23/57 No: T-BF358982-1	WARNER,DAVID,N
11:00 AM	624 KNOWLTON STREET APT #3 WATERLOO WI, 53594	Age: 63 Issued: 10/16/21 Inc #: 21-000474	JEFFERSON CO CIRCUIT CT
Charge	Description	Fine	Collected
343.44(1)(B)	OPERATING WHILE REVOKED (FORFEITURE)	\$200.50	\$0.00

11/16/21	LENZ,ROSS,ELLIOT	DOB: 09/21/83 No: T-BF358557-3	WARNER,DAVID,N
11:00 AM	546 N MONROE ST # 2 WATERLOO WI, 53594	Age: 37 Issued: 08/14/21 Inc #: 21-000361	JEFFERSON CO CIRCUIT CT
Charge	Description	Fine	Collected
344.62(1)	OPERATE MOTOR VEHICLE W/O INSURANCE	\$200.50	\$0.00

11/16/21	NEAVE AGUILAR,BRIAN	DOB: 10/12/99 No: T-BF358976-2	COFFREN,JARED
11:00 AM	208 FRANCES LANE WATERLOO WI, 53594	Age: 22 Issued: 10/14/21 Inc #: 21-000468	JEFFERSON CO CIRCUIT CT
Charge	Description	Fine	Collected
343.05(3)(A)	OPERATE W/O VALID LICENSE (1ST VIOLATION)	\$200.50	\$0.00

11/16/21	NEAVE AGUILAR,BRIAN	DOB: 10/12/99 No: T-BF358977-3	COFFREN,JARED
11:00 AM	208 FRANCES LANE WATERLOO WI, 53594	Age: 22 Issued: 10/14/21 Inc #: 21-000468	JEFFERSON CO CIRCUIT CT
Charge	Description	Fine	Collected
344.62(1)	OPERATE MOTOR VEHICLE W/O INSURANCE	\$200.50	\$0.00

**Court Calendar Report**

**Report Criteria:**

Start Date	End Date	Officer	Court Type
11/01/2021	11/30/2021	ALL	JEFFERSON CO CIRCUIT CT

Court Date	Name	DOB	Ticket No	Officer/Court Type
11/16/21	ROBL,KELLI	06/15/85	T-BF358979-5	CULLEN,NATHANIEL,J
11:00 AM	114 WEST MAIN STREET SUN PRAIRIE WI, 53590	Age: 36	Issued: 10/16/21 Inc #: 21-000473	JEFFERSON CO CIRCUIT CT

Charge	Description	Fine	Collected
344.62(1)	OPERATE MOTOR VEHICLE W/O INSURANCE	\$200.50	\$0.00

Court Date	Name	DOB	Ticket No	Officer/Court Type
11/16/21	ROBL,KELLI	06/15/85	T-BF358980-6	CULLEN,NATHANIEL,J
11:00 AM	114 WEST MAIN STREET SUN PRAIRIE WI, 53590	Age: 36	Issued: 10/16/21 Inc #: 21-000473	JEFFERSON CO CIRCUIT CT

Charge	Description	Fine	Collected
343.05(3)(A)	OPERATE W/O VALID LICENSE (1ST VIOLATION)	\$200.50	\$0.00

Court Date	Name	DOB	Ticket No	Officer/Court Type
11/16/21	RODRIGUEZ GONZALEZ,JESUS	03/16/98	T-BF358990-2	COFFREN,JARED
11:00 AM	244 EDISON STREET WATERLOO WI, 53594	Age: 23	Issued: 10/25/21 Inc #: 21-000490	JEFFERSON CO CIRCUIT CT

Charge	Description	Fine	Collected
343.05(3)(A)	OPERATE W/O VALID LICENSE (1ST VIOLATION)	\$200.50	\$0.00

Court Date	Name	DOB	Ticket No	Officer/Court Type
11/16/21	SERRANO,ARIANA	08/31/02	T-BF358984-3	WARNER,DAVID,N
11:00 AM	207 GREGOR ST WATERLOO WI, 53594	Age: 19	Issued: 10/20/21 Inc #: 21-000482	JEFFERSON CO CIRCUIT CT

Charge	Description	Fine	Collected
346.46(1)	FAIL/STOP AT STOP SIGN	\$175.30	\$0.00

Court Date	Name	DOB	Ticket No	Officer/Court Type
11/16/21	[REDACTED]	[REDACTED]	[REDACTED]	BOLLIG,RANDY,P
11:00 AM	[REDACTED]	[REDACTED]	[REDACTED]	JEFFERSON CO CIRCUIT CT

Charge	Description	Fine	Collected
165-2B(3)	UNDERAGE POSSESSION OF TOBACCO PRODUCTS	\$162.70	\$0.00

Court Date	Name	DOB	Ticket No	Officer/Court Type
11/16/21	TRUMPK,CHAD,H	06/28/85	T-BF358983-2	WARNER,DAVID,N
11:00 AM	W8766 LONDON RD CAMBRIDGE WI, 53523	Age: 36	Issued: 10/18/21 Inc #: 21-000480	JEFFERSON CO CIRCUIT CT

Charge	Description	Fine	Collected
343.44(1)(B)	OPERATING WHILE REVOKED (FORFEITURE)	\$200.50	\$0.00

**Court Calendar Report**

**Report Criteria:**

Start Date	End Date	Officer	Court Type
11/01/2021	11/30/2021	ALL	JEFFERSON CO CIRCUIT CT

Court Date	Name	DOB	Ticket No	Officer/Court Type
11/16/21 11:00 AM	TUSCHEN,TIMOTHY,M 134 E MADISON ST APT 1 WATERLOO WI, 53594	11/12/85 Age: 35	No: T-BH526711-3 Issued: 10/11/21 Inc #: 21-000461	BURNS,RANDY JEFFERSON CO CIRCUIT CT
Charge	Description	Fine	Collected	
343.44(1)(B)	OPERATING WHILE REVOKED (FORFEITURE)	\$200.50	\$0.00	
11/16/21 11:00 AM	WHITING,TYLER,J 165 ANNA CIR COLUMBUS WI, 53925	DOB: 02/24/82 Age: 39	No: T-BF358975-1 Issued: 10/14/21 Inc #: 21-000467	COFFREN,JARED JEFFERSON CO CIRCUIT CT
Charge	Description	Fine	Collected	
341.03(1)	OPERATE AFTER REV/SUSP OF REGISTRATION	\$175.30	\$0.00	
11/29/21 11:00 AM	MARTIN,BRIAN,PAUL 210 1/2 NORTH MONROE WATERLOO WI, 53594	DOB: 05/24/84 Age: 37	No: T-BF358993-5 Issued: 10/27/21 Inc #: 21-000493	WARNER,DAVID,N JEFFERSON CO CIRCUIT CT
Charge	Description	Fine	Collected	
346.63(1)(A)	OWI (4th)	\$0.00	\$0.00	

**Ticket Count: 22**

**Total Fines: \$5789.20**  
**Total Payments: \$0.00**  
**Total Due: \$5789.20**

## Activity Log List

## Report Criteria:

Start Date	End Date	Title	Officer
11/01/2021	11/30/2021		ALL

Title	Notes	Date	Time	Officer
Theft	Officer conducted an investigation of theft of items from porch.	11/02/2021	07:49:00	
Assist public	Officer assisted with a powerline that was down in neighborhood.	11/02/2021	08:53:00	
Assist	Officer requested to assist Dodge County with a louse noise complaint.	11/02/2021	11:34:00	
Traffic stop	Officer conducted a traffic stop, citations issued.	11/02/2021	11:45:00	
Traffic stop	Officer conducted a traffic stop, citation issued.	11/02/2021	13:42:00	
Traffic stop	Officer conducted a traffic stop, citation issued.	11/02/2021	14:18:00	
Traffic stop	Officer conducted traffic stop, citation issued.	11/04/2021	08:55:00	
REFER	NEED TO REFER REPORT ONCE COMPLETED	11/04/2021	14:08:00	KOHN, SASHA, J
Domestic/Disorderly	Officer conducted investigation on a family disturbance.	11/04/2021	15:27:00	
INTERVIEW	Officer Bollig has will be sitting in on an interview with 2 children at school	11/05/2021	07:27:00	KOHN, SASHA, J
Traffic stop	Officer conducted a traffic stop, citations issued.	11/05/2021	08:01:00	
Death investigation	Officer assisted with a death investigation, report taken.	11/05/2021	10:03:00	
Family Trouble	Officer assisted with a custody complaint.	11/05/2021	12:27:00	
Traffic accident	Officer assisted with accident, report taken.	11/08/2021	10:43:00	
Check in	Officer assisted with subject who was checking in with probation and parole, report taken.	11/08/2021	11:38:00	
Dispatch of animal	Officer was requested to dispatch a wounded deer.	11/08/2021	11:51:00	
Dog Bite	Officer filed a report of a dog bite.	11/08/2021	12:12:00	
Assist social services	Officer assisted social services with an interview with a juvenile.	11/09/2021	09:30:00	
Loss	Officer took a report for a subject who lost a ring.	11/09/2021	09:57:00	
Theft	Officer took a report of a theft of an item from a home.	11/09/2021	10:33:00	
Assist	Officer responded to a report of a suicidal subject. Officer assisted and subject was transported.	11/09/2021	12:22:00	
Warrant arrest	Officer's conducted an arrested on a subject that had a warrant.	11/10/2021	10:31:00	
Traffic stop	Officer conducted traffic stop, citation issued.	11/11/2021	09:19:00	
Traffic stop	Officer conducted a traffic stop, citations issued.	11/11/2021	09:47:00	
Interview	Officer assisted Human Services with an interview with a juvenile.	11/11/2021	10:55:00	
Interview	Officer assisted Human Services with an interview of a juvenile.	11/11/2021	12:26:00	
Threats	Officer assisted in handling a report for a subject who was verbally be threatened.	11/12/2021	14:25:00	
Traffic stop	Officer conducted a traffic stop, citation issued.	11/12/2021	15:40:00	
Traffic stop	Officer conducted a traffic stop, citations issued.	11/15/2021	12:39:00	
Assist	Officer was requested to assist Dodge County with an incident.	11/15/2021	15:04:00	
Gas drive off	Officer assisted with a report of a gas drive off.	11/16/2021	10:12:00	
Possible burglary	Officer assisted with a report of possible burglary, at this time it is unfounded.	11/17/2021	11:09:00	
Assist	Officer took a report and assisted with a citizen who lost a form of ID.	11/17/2021	11:55:00	
Traffic stop	Officer conducted a traffic stop, citation issued.	11/17/2021	14:29:00	
Assist	Officer assisted Human Services with an interview.	11/18/2021	13:27:00	
Traffic stop	Officer assisted with a traffic stop, citations issued.	11/19/2021	10:57:00	
Accident	Officer responded and generated a report an accident, no injuries.	11/19/2021	14:05:00	
Traffic stop	Officer conducted a traffic stop, citation issued.	11/19/2021	14:18:00	
Assist	Officer assisted Human Services with a suicidal subject, person was transported.	11/22/2021	13:54:00	
Assist	Officer's assisted Marshall with a traffic stop.	11/23/2021	11:11:00	



Activity Log List

Report Criteria:

Start Date	End Date	Title	Officer
11/01/2021	11/30/2021		ALL

Title	Notes	Date	Time	Officer
Accident	Officer assisted with report of an accident and several citations issued.	11/23/2021	13:10:00	
Accident	Officer assisted with a report of a deer hit within the city limits.	11/24/2021	13:31:00	
Possession	Officer took a report of juvenile in possession of tobacco products.	11/28/2021	13:56:00	
Assist	Officer assisted a subject who was voluntarily admitting themself with a ride to the hospital.	11/28/2021	14:50:00	
Traffic stop	Officer conducted a traffic stop, citations issued.	11/29/2021	08:17:00	
Neighbor dispute	Officer assisted with a neighbor dispute and report has been taken.	11/29/2021	11:11:00	
Traffic stop	Officer conducted a traffic stop, citations issued.	11/30/2021	08:08:00	
Accident	Officer took a report on a accident.	11/30/2021	08:39:00	
Suicidal subject	Officer assisted and took a report for a suicidal subject.	11/30/2021	10:57:00	
Bullying complaint	Officer assisted with a report on a student bullying complaint.	11/30/2021	14:33:00	

# November

## Waterloo Police Department Fleet Maintenance Report

VIN	1FM5K8ABOLGB67	For Period	11/1/2021-11/30/2021
Year	2017	Fuel Cost	\$249.92
Vehicle Description		Miles per gallon	9.25

Date	Fuel	Fuel Cost	Mileage	Maintenance Items	Main. Cost	Officer
11/1/2021	7.73	\$23.96	44541			14
11/2/2021	7.777	\$24.10	44598			14
11/3/2021	9.359	\$29.00	44672			10
11/4/2021	8.712	\$27.00	44738			10
11/5/2021	8.393	\$26.01	44814			10
11/6/2021	6.054	\$18.78	44867			9
11/7/2021	11.735	\$36.37	45005			12
11/8/2021	9.186	\$28.47	45099			12
11/9/2021	8.363	\$25.92	45158			8
11/9/2021	6.947	\$21.53	45221			15
11/10/2021	3.009	\$12.01	45271			11
11/11/2021	7.57	\$23.46	45355			10
11/12/2021	8.48	\$26.26	45399			10
11/13/2021	9.034	\$28.00	45477			10
11/14/2021	9.359	\$29.00	45569			10
11/15/2021	8.954	\$27.75	45671			10
11/16/2021	6.776	\$21.00	45740			10
11/16/2021		\$479.96	45734	plugs, coils, labor		10
11/17/2021	9.36	\$29.01	45809			11
11/18/2021	7.424	\$23.01	45869			11
11/19/2021	6.146	\$19.05	45926			10
11/20/2021	8	\$24.79	45499			10
11/21/2021	8.389	\$26.00	46083			10
11/22/2021	6.776	\$21.00	46150			10
11/23/2021	7.743	\$24.00	46226			10
11/24/2021	7.744	\$24.00	46315			12
11/25/2021	8.312	\$25.76				12
11/26/2021	9.807	\$30.39	46484			12
11/27/2021	8.584	\$26.60	46562			8
11/27/2021	7.09	\$22.00	46630			11

Date	Fuel	Fuel Cost	Mileage	Maintenance Items	Main. Cost	Officer
11/28/2021	8.399	\$26.00	46700			11
11/29/2021	8.073	\$25.02	46776			11
11/30/2021	8.718	\$27.02	46855			11
	249.925	\$1,257.21				









Karl Junginger Memorial Library  
 Mayor/Council/Board Report  
 NOVEMBER 2021

<b>November MONTHLY STATISTICS</b>		Jan	Feb	Mar	Apr	May	June	July	Aug	Sept	Oct	Nov	Dec
Library Card Holders	2020	2349	2360	2375	2377	2378	2386	2401	2414	2426	2440	2452	2460
	2021	2468	2477	2496	2499	2482	2519	2533	2539	2561	2544	2464	
	% of Change	5.07%	4.96%	5.09%	5.13%	4.37%	5.57%	5.50%	5.18%	5.56%	4.26%	0.49%	-100.00%
Checkouts (Circulation)	2020	4118	3528	2468	380	1133	3365	3749	3883	3647	3702	3327	3737
	2021	3263	3312	3601	3425	3352	4483	4826	3764	3475	3499	3245	
	% of Change	-20.76%	-6.12%	45.91%	801.32%	195.85%	33.22%	28.73%	-3.06%	-4.72%	-5.48%	-2.46%	-100.00%
eBook/Audio Checkouts (Circulation)	2020	540	459	451	533	541	578	674	609	522	493	524	492
	2021	593	607	585	536	562	498	573	665	591	655	568	
	% of Change	9.81%	32.24%	29.71%	0.56%	3.88%	-13.84%	-14.99%	9.20%	13.22%	32.86%	8.40%	-100.00%
Library Visits	2020	2683	2877	1577	0	0	1269	1434	938	796	1394	1234	1367
	2021	1396	1259	1539	1125	747	1236	1799	1685	1491	850	1422	0
	% of Change	-47.97%	-56.24%	-2.41%	100.00%	100.00%	-2.60%	25.45%	79.64%	87.31%	-39.02%	15.24%	-100.00%
Meeting Room Use	2020	45	39	23	0	0	0	0	0	3	4	0	1
	2021	1	0	6	5	8	9	3	6	7	2	10	
	% of Change	-97.78%	-100.00%	-73.91%	100.00%	100.00%	100.00%	100.00%	100.00%	133.33%	-50.00%	100.00%	-100.00%
Public Computer Use	2020	326	272	152	0	0	63	83	73	86	93	70	74
	2021	74	92	117	86	87	69	64	70	72	80	84	
	% of Change	-77.30%	-66.18%	-23.03%	100.00%	100.00%	9.52%	-22.89%	-4.11%	-16.28%	-13.98%	20.00%	-100.00%
WiFi Use	2020	324	318	301	109	115	134	136	135	155	153	139	132
	2021	139	166	147	161	154	171	166	159	195	173	182	
	% of Change	-57.10%	-47.80%	-51.16%	47.71%	33.91%	27.61%	22.06%	17.78%	25.81%	13.07%	30.94%	-100.00%
Outreach to local residents -Checkouts <b>NEW WAY 2019</b>	2020	179	95	83	6	0	56	119	55	84	88	95	111
	2021	122	88	96	91	111	109	69	92	142	88	86	
	% of Change	-31.84%	-7.37%	15.66%	1416.67%	100.00%	94.64%	-42.02%	67.27%	69.05%	0.00%	-9.47%	-100.00%
<b>Programs</b>													
Adult Number of Programs	2020	16	11	6	2	2	1	0	1	3	2	1	3
	2021	4	6	4	4	3	6	5	5	6	11	19	
	% of Change	-75.00%	-45.45%	-33.33%	100.00%	50.00%	500.00%	100.00%	400.00%	100.00%	450.00%	1800.00%	-100.00%
Adult Attendance	2020	147	64	37	18	36	6	0	5	13	5	5	28
	2021	46	44	34	25	28	130	35	77	28	112	107	
	% of Change	-68.71%	-31.25%	-8.11%	38.89%	-22.22%	2066.67%	100.00%	1440.00%	115.38%	2140.00%	2040.00%	-100.00%
Teen (12-18) Number of programs	2020	2	2	0	0	0	3	6	3	1	1	1	1
	2021	1	1	1	1	1	8	10	0	1	1	1	
	% of Change	-50.00%	-50.00%	100.00%	100.00%	100.00%	166.67%	66.67%	-100.00%	0.00%	0.00%	0.00%	-100.00%
Attendance (Adult + Teen)	2020	10	15	0	0	0	2	1	0	10	7	10	13
	2021	20	25	22	22	20	154	21	0	0	0	1	
	% of Change	100.00%	66.67%	-100.00%	100.00%	100.00%	7600.00%	2000.00%	#DIV/0!	-100.00%	-100.00%	-90.00%	-100.00%
Children's Number of programs	2020	6	17	5	9	8	15	30	16	5	11	6	4
	2021	6	7	9	6	2	19	20	10	9	11	11	
	% of Change	0.00%	-58.82%	80.00%	-33.33%	-75.00%	26.67%	-33.33%	-37.50%	80.00%	0.00%	83.33%	-100.00%
Attendance (Adult + Child)	2020	99	229	82	125	157	321	405	241	42	208	51	42
	2021	95	184	257	182	84	1133	973	348	58	112	105	
	% of Change	-4.04%	-19.65%	213.41%	45.60%	-46.50%	252.96%	140.25%	44.40%	38.10%	-46.15%	105.88%	-100.00%

\*\* COVID-19 Began in March 2020 we closed library doors on March 16th    Opened doors on June 1st, 2020 to the public.

**Regular meeting of the Waterloo Water & Light Commission held December 7, 2021**

The meeting was called to order by President Tom Bergan at 7:00pm at the Waterloo Utilities office. Present were Commissioners Vern Butzine, Devin Schumann, Tim Thomas, Chuck Wallace, Superintendent Barry Sorenson, Ben Heidemann and Lisa Twarog from Town & Country Engineering.

**Minutes**

It was moved by Schumann, seconded by Butzine, to approve the minutes of the November 9, 2021 meeting. Motion carried.

**Expenditures**

It was moved by Thomas, seconded by Wallace, to approve the payment of the November bills as presented. Motion carried.

**Citizen Input**

None.

**WWTP Soil Borings**

It was moved by Thomas, seconded by Butzine, to approve the soil borings for the WWTP. Motion carried.

**WWTP Final Design Contract**

It was moved by Schumann, seconded by Butzine, to approve the WWTP Final Design contracts. Motion carried.

**WWTP Engineering Contracts**

It was moved by Thomas, seconded by Schumann, to recommend to the City the following Town & Country Engineering contracts RD Application, Prelim Design, RD Coordination, and Final Design. Motion carried.

**Billing Adjustments**

The Commission was made aware of billing adjustments, the cause and rectification.

**General Info**

Sorenson updated the Commission on WWTP plans going out to bid late 2022 with construction to begin in Spring 2023. The Commission was also updated on private well permits.

It was moved by Butzine, seconded by Schumann, to adjourn. Motion carried.

Respectfully submitted,  
Tim Thomas  
Secretary

**List of Bills**

Axley Brynerson	5,603.72	Northeast Wisconsin Technical College	368.22
APG of Southern Wisconsin	20.38	Northern Lakes Service	42.00
Aqua-Aerobic Systems Inc	11,816.00	North Central Labs	970.54
Noel Andrades	352.25	PC Connection	728.56
Border States	5,309.29	Payment Service Network	56.15
BP Credit Card Center	1,777.30	Piggly Wiggly	63.60
C&M Hydraulic Tool Supply	894.35	PSD	8,810.21
City of Waterloo Treasurer	51,491.81	Payroll	77,088.32
Charter Communications	2,899.58	PSC	539.92
Crescent Electric Supply	5,597.16	Resco	2,059.49
F&M Bank	198.64	Solenis LLC	4,086.00
Frontier	348.99	SEERA	1,299.41
GE Grid Solutions	109,200.00	Town & Country	31,176.20
GFC Leasing	85.00	United Liquid Waste Recycling	1,250.00
Hawkins Inc	8,617.90	US Cellular	302.42
Holy Family School	115.00	Unifirst Corp	1,092.09
Howie's Hardware	625.03	UPS	135.78
Infosend	880.54	Visa	3,375.30
Irby	7,830.90	Veolia Water Technologies	22,500.00
Insight FS	482.06	Waterloo Utilities	12,305.09
Jonas Office Products	239.80	Waterloo Building Center	44.00
Catherine Lee	77.05	WE Energies	97.04
LW Allen	9,763.28	Wisconsin Dept. of Revenue	10,963.07
Lou's Gloves	192.00	Wisconsin State Lab	26.00
NWTC Bookstore	697.77	WPPI Energy	212,677.31

Total Disbursements \$617,172.52

**Checking Account #102-613:**

Balance 10/31/21	(\$10,372.92)
Transfer	453,740.00
Disbursements	(403,733.26)
Interest	8.24
Service Charge	(23.13)
Balance 11/30/21	<u>\$39,618.93</u>

**WWTP Account #374-547 (DNR Replacement Fund)**

Balance 10/31/21	\$111,986.05
Deposit	
Transfer for Expenses	
Interest	29.45
Balance 11/30/21	<u>\$112,015.50</u>

**Debt Service Account #3015323:**

Balance 10/31/21	\$41,212.34
Deposit	59,370.00
Bond Payment	
Interest	23.71
Balance 11/30/21	<u>\$100,606.05</u>

**Money Market Account #110-832:**

Balance 10/31/21	281,322.17
Deposits	770,857.64
Transfer	(409,370.00)
Disbursements	(212,677.31)
Interest	521.49
Service Charge	(231.66)
Balance 11/30/21	<u>\$430,422.33</u>

**Transportation Fund**

Balance 10/31/21	\$95,052.99
Transfer	
Balance 11/30/21	<u>\$95,052.99</u>

**Construction Account:**

Balance 10/31/21	1,744,228.60
Transferred in	
Construction Payment	(103,740.00)
Balance 11/30/21	<u>\$1,640,488.60</u>

**CD #7723 (Bond Reserve):**

Balance 10/31/21	310,758.85
Interest	
Transferred in	
Balance 11/30/21	<u>\$310,758.85</u>

**CD #613386 (Bond Reserve):**

Balance 10/31/21	214,116.82
Interest	
Balance 11/30/21	<u>\$214,116.82</u>

**WWTP CD #2875 (DNR Replacement Fund):**

Checking Account #102-613:	\$464,149.88
Interest	
Transfer	
Balance 11/30/21	<u>\$464,149.88</u>



## City Hall

---

**From:** info@whsadopt.org  
**Sent:** Wednesday, December 01, 2021 9:20 AM  
**To:** City Hall  
**Cc:** Mo Hansen  
**Subject:** November Intake Numbers

Here are the numbers for animal intakes in November.  
-Amy Litscher  
Kennel Manager

Feline Strays-5  
Feline Surrenders-0

Canine Strays-0  
Canine Surrenders-0



Virus-free. [www.avg.com](http://www.avg.com)

---

# LEAGUE OF WISCONSIN MUNICIPALITIES MUTUAL INSURANCE COMPANY

## INSURANCE PROPOSAL FOR

## WATERLOO, CITY OF

1/1/2022 - 1/1/2023

*Proposal Number 10342*



League Insurance  
131 W. Wilson Street, Suite 502  
Madison, WI 53703  
(608) 833-9595

Matt Becker, CEO  
[matt@lwwmi.org](mailto:matt@lwwmi.org)



R&R Insurance  
N14 W23900 Stone Ridge Drive  
Waukesha, WI 53188  
(800) 566-7007

Paul Lessila  
[paul.lessila@rrins.com](mailto:paul.lessila@rrins.com)

**Protection for League Members and the communities they call home.  
That is our business and we do it well.**

Created in 1984 and governed by a board of your peers, League Insurance insures more than 465 cities, villages, and special districts. We are 100% member owned and our financial security, broad coverages, and customized services are specifically designed to serve Wisconsin municipalities.

# City of Waterloo

**1/1/2022 to 1/1/2023**

## Proposal

- Premium Comparison
- Proposal
- Statement of Values
- Cyber Liability
- Premier Services

Insured Name: City of Waterloo

Paul Lessila / Karlie Davis  
 Effective: 1/1/2022-1/1/2023

## Premium Comparison

Company Year Coverages	Prior Year	Current Year - By Companies Quoting		
	<u>LWMMI</u> 2021	<u>LWMMI</u> 2022	Difference	
General Liability	\$14,862.00	\$9,951.00	-\$4,911.00	-33.0%
Police Prof Liability	\$5,807.00	\$5,364.00	-\$443.00	-7.6%
Public Officials Liability	\$7,306.00	\$12,317.00	\$5,011.00	68.6%
Auto Liability	\$8,025.00	\$7,213.00	-\$812.00	-10.1%
Auto Physical Damage	\$21,633.00	\$21,997.00	\$364.00	1.7%
<b>Package Total</b>	<b>\$57,633.00</b>	<b>\$56,842.00</b>	<b>-\$791.00</b>	<b>-1.4%</b>
Property	\$24,102.00 <i>MPIC</i>	\$26,845.00 <i>MPIC</i>	\$2,743.00	11.4%
Equipment Breakdown	\$3,934.00 <i>MPIC</i>	\$4,615.00 <i>MPIC</i>	\$681.00	17.3%
Cyber	\$4,617.00 <i>Chubb</i>	\$5,635.00 <i>Chubb</i>	\$1,018.00	22.0%
Crime	\$535.00 <i>Hanover</i>	\$535.00 <i>Hanover</i>	\$0.00	0.0%
<b>Other Coverages Subtotal</b>	<b>\$33,188.00</b>	<b>\$37,630.00</b>	<b>\$4,442.00</b>	<b>13.4%</b>
Workers Compensation	\$34,226.00	\$35,867.00	\$1,641.00	4.8%
<b>Estimated Premium</b>	<b>\$125,047.00</b>	<b>\$130,339.00</b>	<b>\$5,292.00</b>	<b>4.2%</b>
<b>Exposure changes</b>				
	<u>2021</u>	<u>2022</u>	<u>Difference</u>	
<b>Package Changes</b>				
Number of Vehicle	30	31	1	3.3%
Total Vehicle Values	\$4,078,887	\$4,129,988	51,101	1.3%
# of Full Time Police Officers	8.25	7.5	(1)	-9.1%
<b>Property (See Additional Page)</b>				
<b>Work Comp (See additional page)</b>				

Insured Name: City of Waterloo

Effective: 1/1/2022-1/1/2023

## Workers' Compensation Comparison

Code	Classification	2021 Payroll Exposure	2021 Rate	2021 Premium	2022 Payroll Exposure	2022 Rate	2022 Premium	Exposure Difference	Rate Difference	% Rate Difference	Premium Difference
7520	Waterworks Operation	120,000	3.74	4,488	95,000	3.45	3,278	(25,000)	-0.29	-7.8%	(1,210)
7539	Electric Power Company	268,000	1.59	4,261	370,000	1.52	5,624	102,000	-0.07	-4.4%	1,363
7704	Fire Dept Non-Volunteer	107,000	3.70	3,959	113,000	3.50	3,955	6,000	-0.20	-5.4%	(4)
7709	Fire Department - Volunteer <i>Flat Charge based on Population</i>	4,500		2,802	4,810		2,990				188
7710	Civil Defense Workers	20,537	4.02	826	16,000	3.72	595	(4,537)	-0.30	-7.5%	(231)
7720	Police Officers	503,000	3.17	15,945	494,000	2.89	14,277	(9,000)	-0.28	-8.8%	(1,668)
8810	Clerical Office	512,000	0.19	973	415,000	0.19	789	(97,000)	0.00	0.0%	(184)
9412	Municipal Operations-Cty/Town	423,582	3.61	15,291	449,000	3.49	15,670	25,418	-0.12	-3.3%	379
<b>Totals</b>		<b>1,958,619</b>		<b>48,545</b>	<b>1,956,810</b>		<b>47,178</b>	<b>(2,119)</b>			<b>(1,367)</b>
Experience Mod			0.75	(12,136)		0.81	(8,964)		0.06		3,172
Premium Discount			6.60%	(2,403)		6.70%	(2,567)		0.10%		(164)
Expense Constant				220			220				0
Terrorism Coverage			0.00	0		0.00	0				0
<b>Total Premium</b>				<b>\$34,226</b>			<b>\$35,867</b>				<b>\$1,641</b>

Insured Name: City of Waterloo  
 Effective: 1/1/2022-1/1/2023

## Property Comparison

	Prior Year <b>MPIC</b> 2021	Current Year <b>MPIC</b> 2022	Difference	
<b>Building, BPP, PITO</b>				
Premium	\$22,258.00	\$25,327.00	\$3,069.00	14%
Coverage Limit	49,666,383	53,712,633	\$4,046,250.00	8%
Rate	\$0.0448	\$0.0472	\$0.00	5%
Deductible	\$10,000.00	\$10,000.00	\$0.00	0%
<b>Contractor's Equipment</b>				
Premium	\$1,599.00	\$1,273.00	-\$326.00	-20%
Coverage Limit	761,214	606,099	-\$155,115.00	-20%
Rate	\$0.21	\$0.210	\$0.00	0%
Deductible	\$1,000.00	\$1,000.00	\$0.00	0%
<b>Bridges</b>				
Premium	\$245.00	\$245.00	\$0.00	0%
Coverage Limit	426,807	426,807	\$0.00	0%
Rate	\$0.0574	\$0.0574	\$0.00	0%
Deductible	\$10,000.00	\$10,000.00	\$0.00	0%
<b>Equipment Breakdown</b>				
Premium	\$3,934.00	\$4,615.00	\$681.00	17%
Coverage Limit	49,666,383	53,712,633	\$4,046,250.00	8%
Rate	\$0.0079	\$0.0086	\$0.00	9%
Deductible	\$1,000.00	\$1,000.00	\$0.00	0%
<b>Property Total</b>	<b>\$28,036.00</b>	<b>\$31,460.00</b>	<b>\$3,424.00</b>	<b>12%</b>

**NOTES:**

\$1,000 Deductible for all buildings, Contents, & PITO (\$3,870,171 TIV) located at 900 Industrial Lane Fire Station

Credit applied for total exclusion of concrete TIV at \$7,691,989 at building rate of \$.0536

# Proposal

# LEAGUE INSURANCE – COVERAGE HIGHLIGHTS

## COVERAGE PROVIDED FOR:

- Elected/Appointed Officials
- Commissions
- Departments
- Employees
- Mutual Aid Assistance
- Volunteers

## COMPREHENSIVE COVERAGE INCLUDES:

- Auto Liability
- Auto Physical Damage
- Cyber Liability
- Employee Benefits Liability
- Employment Practices Liability
- General Liability
- Law Enforcement
- Public Officials
- Self-Insured Retention Workers' Compensation
- Workers' Compensation

## ADDITIONAL COVERAGE ENHANCEMENTS

### *Liability:*

- Airports
- Back Wages in Employment Claims
- Breach of Contract
- Care, Custody, & Control
- Communicable Disease
- Contractual Liability
- Cyber
- Damages to Rented Premises
- Dams
- Defense Costs in Addition to Limit
- Discrimination
- Drones
- EEOC actions
- Failure to Supply
- Land Use, Permits, & Zoning Claims
- Medical Payments
- No Fault Sewer Backup Optional Coverage
- Non-monetary Claims
- Occurrence Based
- Pollution
- Sexual Harassment/Abuse Coverage
- Special Events Included
- Tax Assessment Claims
- Volunteers
- Watercraft
- Wrongful Termination

### *Auto:*

- Automatic New Auto Coverage
- Autos of Others in Your Care, Custody, or Control
- Commandeered Autos
- Hired Auto Physical Damage
- Hired/Non-owned
- Lease Gap
- Personal Auto Physical Damage Deductible Reimbursement
- Temporary Transportation Expense
- Towing Expense
- Uninsured/Underinsured



## PREMIER SERVICES – CUSTOMIZED FOR YOU

### HUMAN RESOURCES ASSISTANCE

League Insurance has partnered with *Stafford Rosenbaum LLP* to provide the following human resources services:

- HR Hotline – phone assistance with HR-related issues.
- Talent Management – support with recruitment, hiring, background screening, onboarding, performance management, coaching, feedback, disciplinary counseling, termination management, and organizational and staff development.
- Employment Law Compliance – WI and Federal Fair Employment, wage & hour, safety, FMLA, I-9 Employment Verification, and more.
- Documents – development/review of job descriptions, **handbooks, policies, procedures**, and forms customized for the municipality.
- Compliance and HR practices assessments and development of remedial plans.
- Workplace Training – related to compliance and HR-related topics for supervisors and/or employees.
- Workplace investigations.
- Sample handbooks, toolkits addressing various HR subjects and best practices, and online harassment and discrimination training webinars.

### EMPLOYEE SAFETY & RISK MANAGEMENT

With loss control resources provided by United Heartland, we can analyze loss trends and municipal operations to **customize a safety program for your community**. Included are comprehensive safety manuals, job site analysis, newsletters, webinars, and information on many topics including:

- Confined Space
- Excavating/Trenching
- Hearing Conservation
- Ladder Safety/Fall Protection
- Lawn Care/Mowers/Trimming/Landscaping
- Lockout Tagout/Electrical Arc Flash
- Motor Vehicle & Construction Equipment Safety
- Outside Contractor Qualification
- Power Platforms/Aerial Lifts
- Respiratory Protection
- Rigging/Slings/Hoists
- Tools – Hand Tools/Power Tools
- Tree Trimming/Chainsaw & Chipper Safety
- Water Hazards – Pools, Ponds, Lakes
- Welding, Cutting, or Brazing
- Work Zone Safety/Traffic Control

### LEAGUE INSURANCE UNIVERSITY

League Insurance has partnered with *Lexipol* to provide self-paced online courses *written specifically* for local government and public safety professionals. Courses are available on demand from any computer or mobile device with internet access, 24/7.

- League Insurance University offers all employees access to over **200 online training topics** including HR & Management, Safety, Public Works, Law Enforcement, and much more.
- For Water and Wastewater, League Insurance University courses can be used to fulfill annual training hours requirements. Wastewater professionals will simply need to submit their certificate of course completion directly to the DNR for training approval.
- For law enforcement, League Insurance Police University can be used to fulfill 8 of the 24 hours of annual training requirements with Department level approval.

---

## CYBER UNIVERSITY

League Insurance is partnered with leading cyber insurance provider, *Tokio Marine HCC*. With cyber liability coverage from League Insurance, you have **access to state-of-the-art cyber coverage and resources** including:

- Training courses on many topics including ransomware, phishing emails, network security, and more.
- Sample policies and procedures for best practices and breach response plans.
- Cyber security advisors for technical information and scenario planning.

---

## LAW ENFORCEMENT POLICIES/PROCEDURES ASSISTANCE

League Insurance members are **eligible to receive reimbursement** for updating law enforcement and fire department manuals through an accredited policy manual service provider, as well as reimbursement for law enforcement accreditation.

---

## REBOUND RETURN TO WORK PROGRAM

League Insurance has contracted with *Rebound*, a company which specializes in rehabilitation of injured municipal employees. The program gets your employees seen by top specialists quickly, and with better outcomes. This helps employees recover and saves departments money. Under the *Rebound* program, members are **100% reimbursed** by League Insurance for Rebound expenses incurred.

---

## NURSE TRIAGE & TELEHEALTH

League Insurance is partnered with *CorVel* to provide nurse triage and telehealth services. CorVel's proactive healthcare solution offers injured workers the following medical services:

- Nurse Triage – **24-7 access to registered nurse hotline** to evaluate injuries to determine immediate medical needs.
  - Telehealth – Provides immediate referral to medical physicians when needed via computer, tablet, or phone.
-

# YOUR LEAGUE INSURANCE TEAM

---

## LEAGUE INSURANCE

131 W. Wilson Street  
Suite 502  
Madison, WI 53703  
(608) 833-9595

Matt Becker, CPCU  
CEO  
[matt@lwmmi.org](mailto:matt@lwmmi.org)

---

## R & R INSURANCE SERVICES

N14 W23900 Stone Ridge Drive  
Waukesha, WI 53188

Paul Lessila  
[paul.lessila@rrins.com](mailto:paul.lessila@rrins.com)

---

## WORKERS COMPENSATION CLAIMS ADMINISTRATOR

United Heartland  
PO Box 3026  
Milwaukee, WI 53201-3026  
(800) 258-2667

Denise Kawczynski, Senior Claims Representative  
[denise.kawczynski@unitedheartland.com](mailto:denise.kawczynski@unitedheartland.com)  
(262) 787-7646

---

## LIABILITY CLAIMS ADMINISTRATOR

Statewide Services, Inc.  
PO Box 5555  
Madison, WI 53705  
(800) 858-1536

Anthony Conlin, Attorney at Law  
[aconlin@statewidesvcs.com](mailto:aconlin@statewidesvcs.com)  
(608) 828-5461

---

## FINANCIAL ADMINISTRATOR

Strohm Ballweg, LLP  
9701 Brader Way  
Suite 301  
Middleton, WI 53562  
(608) 821-0600

Tom Dawson, CPA  
Partner  
[tdawson@strohmballweg.com](mailto:tdawson@strohmballweg.com)

---



# League Insurance Quote Summary

Policy Effective Date: 1/1/2022

Proposal Number: 10342

Insured Name: Waterloo, City of  
 Contact Name: \_\_\_\_\_  
 Contact Phone: \_\_\_\_\_  
 Contact Email: \_\_\_\_\_

Agency: R & R Insurance Services  
 Agent Name: Lessila, Paul  
 Agent Email: paul.lessila@rrins.com

## PREMIUM:

	Expiring Policy			Renewal		
	Deductible	Limit	Premium	Deductible	Limit	Premium
General Liability	0	5,000,000	14,862	0	5,000,000	9,951
Police Professional Liability	2,500	5,000,000	5,807	2,500	5,000,000	5,364
Public Official Liability	2,500	5,000,000	7,306	2,500	5,000,000	12,317
Auto Liability	0	5,000,000	8,025	0	5,000,000	7,213
Auto Physical Damage			21,633			21,997
Airport	N/A	N/A	0	N/A	N/A	0
Dam	N/A	N/A	0	N/A	N/A	0
No Fault Sewer						
Railroad	N/A	N/A	0	N/A	N/A	0
UM & UIM Higher Limit	N/A	N/A	0	N/A	N/A	0
Cyber	2,500	25,000	0	2,500	25,000	0
<b>Total Premium</b>			<b>57,633.00</b>			<b>56,842.00</b>

## EXPOSURES AND LIMITS:

	Expiring	Renewal
<b>Base Exposures:</b>		
Total Payroll	1,881,460	1,954,990
Number for FTE Police	8.25	7.50
Number of Vehicles (Auto Liability)	29	31
Population	3,341	3,366
APD – Total Original Cost	4,078,887	4,129,988
APD – Total Number of Vehicles	30	31
<b>Supplemental Exposures:</b>		
UM & UIM limit	\$25K Per Person / \$50k Occurrence	\$25K Per Person / \$50k Occurrence
Cyber Limit	25,000	25,000
Operating Expenditures (Cyber)	N/A	N/A
Number of Dams		
Number of Railroads	N/A	N/A
Airport Coverage	N/A	N/A
Airport Refueling	N/A	N/A
Population Base for No Fault Sewer Coverage	3,341	3,366

## ADDITIONAL INSURED:

Name	Reason
Dairyland Leasing, LLC	Designated Leased Items: Bobcat S595 Skid-Steer Loader, SN: B3NL13327 \$34,100 Bobcat 68" Ange Broom, SN: 231327588 \$3,600 Bobcat 74" Bucket, SN: N/A \$780 Bobcat 48" Pallet Forks, SN: N/A \$520

*Proposed coverages, no coverage has been bound.*

## League Insurance – Auto Physical Damage Schedule

Municipality: Waterloo, City of

Effective Date: 1/1/2022

Expiration Date: 1/1/2023

Year	Make	Model	Vehicle Type	VIN #	Dept. (optional)	Zip Code (Garaged at Night)	Parked Inside (i) or Outside (o)	Is Garage Location in a Flood Zone?	Deductible	Original Cost New	Coverage Type (Replacement Cost or Actual Cash Value)
1931	Seagrave	Fire Truck	Antique	1234	Fire	53594	Inside	No	\$500	\$10,000	Stated Value - Antique
1985	Seagrave	Fire Truck	Fire Other	1F9E128H0FCST2133	Fire	53594	Inside	No	\$500	\$144,000	Actual Cash Value
1987	Peterbilt	Fire Truck	Fire Other	1XPALAOX9HN213461	Fire	53594	Inside	No	\$500	\$137,000	Actual Cash Value
1990	Ford	LS8000	Fire Other	1FDXS82APLVA38293	Fire	53594	Inside	No	\$500	\$135,000	Actual Cash Value
1998	International	Bucket Truck	Dump Truck	1HTSCAAN3WH552072	Utilities	53594	Inside	No	\$500	\$90,000	Actual Cash Value
2001	Ford	F450	Fire Other	1FDXW47F11EB70429	Fire	53594	Inside	No	\$500	\$73,300	Actual Cash Value
2001	Emergency	One Fire	Fire Other	4EN3AAA8611004215	Fire	53594	Inside	No	\$500	\$410,000	Actual Cash Value
2004	International	7400	Dump Truck	1HTWDADR34J089126	Utility	53594	Inside	No	\$500	\$187,150	Actual Cash Value
2004	Chevrolet	Silverado	Pickup	1GCHK24414E147670	Utilities	53594	Inside	No	\$500	\$26,278	Actual Cash Value
2005	Seagrave	Fire Truck	Fire Other	1F9E628T65CST2030	Fire	53594	Inside	No	\$500	\$415,000	Actual Cash Value
2005	Freightliner	AD170	Rescue	1FVACVCS25HU8213	Fire	53594	Inside	No	\$500	\$153,478	Actual Cash Value
2008	Chevrolet	Pickup	Fire Other	2GCEDK19J781142265	Fire	53594	Inside	No	\$500	\$10,500	Actual Cash Value
2010	International	Dump Truck	Dump Truck	1HTWDAAR1AJ190097	City	53594	Inside	No	\$500	\$64,327	Actual Cash Value
2010	Kenworth	T800 Tanker Fire Truck	Fire Other	1NKDL00X3AJ271876	Fire	53594	Inside	No	\$500	\$227,400	Actual Cash Value
2011	Ford	Truck	Pickup	1FDUF5GY6BEC17465	City	53594	Inside	No	\$500	\$39,595	Actual Cash Value
2011	Freightliner	Truck	Dump Truck	1FVACXDT1BDBB0949	Utilities	53594	Inside	No	\$500	\$155,387	Actual Cash Value
2013	Chevrolet	Silverado	Pickup	1GB0KVCGXZ269922	Utilities	53594	Inside	No	\$500	\$35,716	Actual Cash Value
2015	Freightliner	Ambulance	Rescue	1FVACVCYOFHGF1331	Fire	53594	Inside	No	\$500	\$223,410	Replacement Cost
2015	Freightliner	108SD	Dump Truck	1FVAG5CY6FHGD1718	City	53594	Inside	No	\$500	\$105,000	Replacement Cost
2016	Ford	Explorer	Fire Other	1FM5K8AR1GGC36083	Fire	53594	Inside	No	\$500	\$27,250	Actual Cash Value
2016	International	4300 Aerial Bucket Truck	Dump Truck	1HTMMMMN3GH271927	Utilities	53594	Inside	No	\$500	\$158,774	Replacement Cost
2017	Chevrolet	Silverado	Pickup	1GCOKUEGXH7164483	DPW	53594	Inside	No	\$500	\$32,585	Replacement Cost
2017	Ford	Explorer	Police	1FM5K8AR8HGB65062	Police	53594	Inside	No	\$500	\$26,769	Replacement Cost
2017	Chevrolet	Silverado	Pickup	1GCOKUEGXHZ226660	Utilities	53594	Inside	No	\$500	\$27,938	Replacement Cost
2018	Freightliner	Truck	Dump Truck	1FVAG5FE0JHJRA4522	City	53594	Inside	No	\$500	\$125,000	Replacement Cost
2019	Ford	F350	Pickup	1FDRF3H66KEG35550	Utilities	53594	Inside	No	\$500	\$45,501	Replacement Cost
2020	Spartan	Gladiator	Fire Other	4S7AU2E98LC088423	Fire	53594	Outside	No	\$500	\$800,000	Replacement Cost
2020	International	HV570	Dump Truck	1HTEVTAR0LH865021	DPW	53594	Outside	No	\$500	\$135,000	Replacement Cost

*Proposed coverages, no coverage has been bound.*

2020	Ford	Explorer	Police	1FM5K8AB0LGB67318	Police	53594	Outside	No	\$500	\$34,005	Replacement Cost
2021	Ford	Explorer	Police	1FM5K8AB3MGB18308					\$500	\$40,120	Replacement Cost
2021	Chevrolet	Silverado	Pickup	1GC1YLE73MF265003					\$500	\$34,505	Replacement Cost

**Total Vehicle Count:** 31      **Policy Totals:** \$ 4,129,988

- (1) Original Cost New (OCN) is the retail cost the original purchaser paid for the vehicle. This includes the value before any credit for a trade-in.  
(2) Coverage Type is determined by underwriting and is based on the vehicle age and value.



## Commercial Property

### Subjects of Insurance

Subjects of Insurance	Limit	Deductible
Blanket Building, Personal Property & Property in the open	\$53,712,633	\$10,000
Equipment Breakdown	\$53,712,633	\$1,000
Contractor's Equipment	\$606,099	\$1,000
Bridges	\$426,807	\$10,000

### Additional information

Subjects of Insurance
\$1,000 Deductible for all buildings, contents, and PITO (\$3,870,171 TIV) located at 900 Industrial Lane – Fire station





## Crime

### Subject of Insurance

Coverage	Limit	Deductible
Employee Dishonesty	\$100,000	\$500
Forgery or Alteration	\$50,000	\$500
Inside the Premises – Theft of Money & Securities	\$50,000	\$500
Inside the Premises – Robbery or Safe Burglary of other property	\$50,000	\$500
Outside the Premises	\$50,000	\$500
Computer Fraud	\$50,000	\$500
Funds Transfer Fraud	\$50,000	\$500

## Workers Compensation

### Employers Liability & Increased Limits

Coverage	Each Accident	Disease Policy	Disease Employee
WC & Employer's liability	\$100,000	\$500,000	\$100,000

### Worker's Comp Rating Basis

Class Code	Classification	Rate	Exposure
7520	Waterworks Operation	3.45	95,000
7539	Electric Power Co NOC	1.52	370,000
7704	Firefighters	3.50	113,000
7709	Fire Department – Volunteer		4,810
7710	Civil Defense Worker's	3.72	16,000
7720	Police Officers	2.89	494,000
8810	Clerical Office	0.19	415,000
9414	Municipal Operations	3.49	449,000

Experience Mod	Premium Discount
.81	6.7%

*The exposures shown above are subject to audit and may result in an additional or return premium depending on your actual exposures for the policy term. The audit could also result in additional classifications not shown in this proposal.*



# Statement of Values



## **MPIC Coverage Highlights**

### **As of September 1, 2020 Policy Filing**

MPIC has included numerous coverages in our manuscript coverage form that are designed specifically help address coverage concerns that are unique to Wisconsin public entities.

- Blanket Plus coverage - Coverage up to **125%** of your Total Insured Value for any loss
- A single deductible applies to a covered loss that might impact more than one property type
- Contactor's Equipment coverage included for all items up to \$25,000 - Additional coverage in excess of \$25,000 is provided if scheduled and endorsed to the policy.
- Valuable Records coverage with full coverage limits, once deductible is met
- \$10,000,000 extra expense coverage; Additional coverage available
- \$5,000,000 for Asbestos Cleanup, Abatement and Removal from a covered loss
- \$5,000,000 Ordinance and Law Coverage
- \$1,000,000 Coverage for Unscheduled Buildings and Property in the Open
- Newly Acquired Property – Included at no charge during the current policy period. Property must be scheduled before the next renewal for continued coverage in future policy periods
- Coverage for Police Dogs and Horses up to \$25,000; a \$1,000 deductible applies to this coverage
- Automatic Builder's Risk coverage for projects up to \$2,500,000 in value
- \$2,000,000 coverage for Pollutants from a covered peril
- \$5,000,000 Flood Coverage of for property not located in an "A" zoned flood plain per policy period
- \$5,000,000 Earthquake Coverage per policy period
- \$50,000 coverage per Fine Art item or collection included. Additional coverage available
- \$2,500,000 in Builders Risk Coverage; Coverage up to \$30,000,000 available by endorsement
- \$50,000 coverage for Excavation, Grading and Filling
- \$100,000 coverage Building Foundations and Footings
- Coverage for Trees and Shrubs damaged by any covered peril within 100' of a building
- \$25,000 coverage for Fire Department Service Charges
- \$50,000 coverage for Documentation of Loss Coverage
- \$100,000 coverage for Architectural and Engineering Design
- Include \$25,000 coverage for Computer Service Interruption
- Direct Damage from Utilities is a covered peril for Buildings, Personal Property and PITO
- \$50,000 limited coverage for Fungus related to a covered peril, per policy period
- A single deductible applies to a covered loss that might impact more than one property type
- Emergency support equipment contained in/on emergency response vehicles subject to a \$1,000 deductible.
- Coverage available for scheduled Pedestrian Bridges and piers and wharfs
- Terrorism Coverage Included

# STATEMENT OF VALUES

## MUNICIPAL PROPERTY INSURANCE COMPANY

Coverage Amount - 53,712,633

Site	Bldg	Description	Year Built	Floors	Square Footage	Building CRN	Content CRN
<b>1 DEPARTMENT OF PUBLIC WORKS</b>							
	1	DEPARTMENT OF PUBLIC WORKS 211 HENDRICKS STREET WATERLOO WI 53594	2008	1	9,790	\$1,056,991	\$89,022
	2	DPW 211 HENDRICKS STREET WATERLOO WI 53594	0	1	1,950	\$64,070	\$11,032
	3	DPW 211 HENDRICKS STREET WATERLOO WI 53594	0	1	2,400	\$78,889	\$11,032
		Property in the open					\$25,628
		<b>DEPARTMENT OF PUBLIC WORKS (1) Total</b>				<b>\$1,199,950</b>	<b>\$136,714</b>
<b>2 SALT SHED - DPW</b>							
	1	SALT SHED - DPW 211 HENDRICKS STREET WATERLOO WI 53594	0	1	1,408	\$61,618	\$15,000
		<b>SALT SHED - DPW (2) Total</b>				<b>\$61,618</b>	<b>\$15,000</b>
<b>3 VET'S PARK</b>							
	1	VET'S PARK 100 NORTH MONROE STREET WATERLOO WI 53594	0	1	850	\$56,827	\$0
		<b>VET'S PARK (3) Total</b>				<b>\$56,827</b>	<b>\$0</b>
<b>4 CITY BLDG - MBC</b>							
	1	CITY BLDG - MBC 117 EAST MADISON STREET WATERLOO WI 53594	0	1	2,000	\$249,706	\$11,032
		<b>CITY BLDG - MBC (4) Total</b>				<b>\$249,706</b>	<b>\$11,032</b>
<b>5 MUNICIPAL BUILDING</b>							
	1	MUNICIPAL BUILDING 136 NORTH MONROE STREET WATERLOO WI 53594	1978	1	16,982	\$5,021,766	\$736,297
		Property in the open					\$108,975
		<b>MUNICIPAL BUILDING (5) Total</b>				<b>\$5,021,766</b>	<b>\$845,272</b>
<b>6 PITO - Various</b>							
		Property in the open					\$44,571
		<b>PITO - Various (6) Total</b>				<b>\$0</b>	<b>\$44,571</b>
<b>7 CABLE OFFICE</b>							
	1	CABLE OFFICE 856 NORTH MONROE WATERLOO WI 53594	0	1	200	\$	\$17,651

# STATEMENT OF VALUES

## MUNICIPAL PROPERTY INSURANCE COMPANY

Coverage Amount - 53,712,633

Site	Bldg	Description	Year Built	Floors	Square Footage	Building CRN	Content CRN
		<b>CABLE OFFICE (7) Total</b>				<b>\$0</b>	<b>\$17,651</b>
<b>8</b>		<b><i>KARL JUNGINGER MEMORIAL LIBRARY</i></b>					
	1	KARL JUNGINGER MEMORIAL LIBRARY 625 NORTH MONROE STREET WATERLOO WI 53594  Property in the open	2001	1	11,549	\$3,110,580	\$1,052,013   \$68,639
		<b>KARL JUNGINGER MEMORIAL LIBRARY (8) Total</b>				<b>\$3,110,580</b>	<b>\$1,120,652</b>
<b>9</b>		<b><i>FIRE STATION-HEADQUARTERS</i></b>					
	1	FIRE STATION 900 INDUSTRIAL LANE WATERLOO WI 53594	1998	1	15,210	\$2,984,668	\$634,468
	2	FIRE STATION-EQUIPMENT BLDG 900 INDUSTRIAL LANE WATERLOO WI 53594	0	1	3,000	\$97,943	\$5,516
	3	FIRE STATION-TRAINING TOWER 900 INDUSTRIAL LANE WATERLOO WI 53594  Property in the open	0	4	10,000	\$65,964	\$0   \$75,213
		<b>FIRE STATION-HEADQUARTERS (9) Total</b>				<b>\$3,148,575</b>	<b>\$715,197</b>
<b>10</b>		<b><i>FIREMAN'S PARK - P</i></b>					
	1	BAND STAND 500 NORTH PARK AVE WATERLOO WI 53594	0	1	1,000	\$80,672	\$0
	2	BANK BUILDING 500 NORTH PARK AVE WATERLOO WI 53594	0	1	625	\$29,305	\$0
	3	BINGO HALL 500 NORTH PARK AVE WATERLOO WI 53594	0	1	3,000	\$163,685	\$5,516
	4	Carousel 500 PARK AVENUE WATERLOO WI 53594	1927	1	2,208	\$319,570	\$959,811
	5	FIREMANS PARK- Reunion HALL 500 NORTH PARK STREET WATERLOO WI 53594	0	1	3,300	\$248,592	\$3,861
	6	FIREMANS PARK-BATHROOM 500 NORTH PARK STREET WATERLOO WI 53594	0	1	3,000	\$252,380	\$0
	7	FIREMANS PARK-STORAGE 500 NORTH PARK STREET	0	1	3,200	\$103,738	\$15,445

# STATEMENT OF VALUES

## MUNICIPAL PROPERTY INSURANCE COMPANY

Coverage Amount - 53,712,633

Site	Bldg	Description	Year Built	Floors	Square Footage	Building CRN	Content CRN
		WATERLOO WI 53594					
	8	Gazebo 500 NORTH PARK AVE WATERLOO WI 53594	0	1	750	\$25,962	\$5,516
	9	Lower Shed 500 NORTH PARK AVE WATERLOO WI 53594	0	1	1,600	\$53,707	\$24,271
	10	PAVILION 500 PARK AVENUE WATERLOO WI 53594	1906	1	14,437	\$1,715,521	\$65,973
	11	Roundhouse 500 NORTH PARK AVE WATERLOO WI 53594	0	1	1,000	\$77,775	\$0
	12	Upper Shed 500 NORTH PARK AVE WATERLOO WI 53594	0	2	3,200	\$102,735	\$5,516
	13	Wyso Concessions 500 NORTH PARK AVE WATERLOO WI 53594	0	1	2,000	\$65,741	\$0
	14	Wyso Storage & Field Shed 500 NORTH PARK AVE WATERLOO WI 53594	0	1	900	\$59,947	\$11,032
		Property in the open					\$1,195,090
		<b>FIREMAN'S PARK - P (10) Total</b>				<b>\$3,299,330</b>	<b>\$2,292,031</b>
<b>11</b>		<b><i>SOUTH MONROE SUBSTATION - U</i></b>					
	1	SUBSTATION 206 SOUTH MONROE STREET WATERLOO WI 53594	1967	1	0	\$988,463	\$0
		Property in the open					\$8,134
		<b>SOUTH MONROE SUBSTATION - U (11) Total</b>				<b>\$988,463</b>	<b>\$8,134</b>
<b>12</b>		<b><i>WEST MADISON SUBSTATION - U</i></b>					
	1	SUBSTATION 677 WEST MADISON STREET WATERLOO WI 53594	1985	1	0	\$989,021	\$0
		Property in the open					\$8,023
		<b>WEST MADISON SUBSTATION - U (12) Total</b>				<b>\$989,021</b>	<b>\$8,023</b>
<b>13</b>		<b><i>WATER TOWER - U</i></b>					
	1	WATER TOWER 212 SQUIRE STREET WATERLOO WI 53594	1910	1	0	\$766,390	\$0
		<b>WATER TOWER - U (13) Total</b>				<b>\$766,390</b>	<b>\$0</b>

# STATEMENT OF VALUES

## MUNICIPAL PROPERTY INSURANCE COMPANY

Coverage Amount - 53,712,633

Site	Bldg	Description	Year Built	Floors	Square Footage	Building CRN	Content CRN
<b>14 WATER STORAGE TANK - U</b>							
	1	WATER STORAGE TANK 735 HERRON COURT WATERLOO WI 53594	1964	1	1,256	\$998,269	\$0
		Property in the open					\$2,674
		<b>WATER STORAGE TANK - U (14) Total</b>				<b>\$998,269</b>	<b>\$2,674</b>
<b>15 WELL HOUSE 4 - U</b>							
	1	WELL HOUSE 461 WEST PORTER STREET WATERLOO WI 53594	1975	1	755	\$449,048	\$0
		Property in the open					\$18,720
		<b>WELL HOUSE 4 - U (15) Total</b>				<b>\$449,048</b>	<b>\$18,720</b>
<b>16 WELL HOUSE 2 - U</b>							
	1	WELL HOUSE 661 LUM AVENUE WATERLOO WI 53594	1996	1	2,331	\$897,317	\$0
		Property in the open					\$18,720
		<b>WELL HOUSE 2 - U (16) Total</b>				<b>\$897,317</b>	<b>\$18,720</b>
<b>17 WELL HOUSE 1 - U</b>							
	1	WELL HOUSE 120 MEADE STREET WATERLOO WI 53594	1986	1	462	\$323,359	\$0
		<b>WELL HOUSE 1 - U (17) Total</b>				<b>\$323,359</b>	<b>\$0</b>
<b>18 WASTEWATER TREATMENT PLANT - U</b>							
	1	ADMINISTRATION BUILDING 401 HENDRICKS STREET WATERLOO WI 53594	1952	1	5,014	\$2,567,042	\$164,933
	2	AERATION BASIN [ADD01] 401 HENDRICKS STREET WATERLOO WI 53594	1986	1	15,227	\$4,316,548	\$0
	3	CHLORINE CONTACT/UV BASIN [ADD04] 401 HENDRICKS STREET WATERLOO WI 53594	1986	1	1,341	\$500,638	\$0
	4	FINAL CLARIFIER 1 401 HENDRICKS STREET WATERLOO WI 53594	1986	1	1,256	\$565,154	\$0
	5	FINAL CLARIFIER 2 401 HENDRICKS STREET WATERLOO WI 53594	1986	1	1,256	\$565,154	\$0



# STATEMENT OF VALUES

## MUNICIPAL PROPERTY INSURANCE COMPANY

Coverage Amount - 53,712,633

Site	Bldg	Description	Year Built	Floors	Square Footage	Building CRN	Content CRN
	6	PHOSPHOROUS BUILDING 401 HENDRICKS STREET WATERLOO WI 53594	1998	1	1,416	\$442,362	\$40,267
	7	RAS/WAS PUMP STATION [ADD03] 401 HENDRICKS STREET WATERLOO WI 53594	1986	1	1,108	\$531,726	\$0
	8	SCREEN BUILDING 401 HENDRICKS STREET WATERLOO WI 53594	1986	1	1,458	\$767,505	\$0
	9	SECONDARY INFLUENT PUMP STATION [ADD02] 401 HENDRICKS STREET WATERLOO WI 53594	1986	1	511	\$453,394	\$0
	10	SERVICE BUILDING 401 HENDRICKS STREET WATERLOO WI 53594	1952	1	4,032	\$2,582,864	\$55,051
	11	SLUDGE STORAGE TANK 401 HENDRICKS STREET WATERLOO WI 53594	1952	1	5,675	\$2,023,838	\$0
		Property in the open					\$77,330
		<b>WASTEWATER TREATMENT PLANT - U (18) Total</b>				<b>\$15,316,225</b>	<b>\$337,581</b>
<b>19</b>		<b>WEST MADISON STREET LIFT STATION - U</b>					
	1	PITO - LIFT STATION WEST MADISON STREET WATERLOO WI 53594	0	1	300	\$188,422	\$0
		<b>WEST MADISON STREET LIFT STATION - U (19) Total</b>				<b>\$188,422</b>	<b>\$0</b>
<b>20</b>		<b>KRAUSE SUB PUMP STATION - U</b>					
	1	PITO - PUMP STATION LOT 1 - KRAUSE SUB HIAWATHA TL. WATERLOO WI 53594	0	1	300	\$99,392	\$0
		<b>KRAUSE SUB PUMP STATION - U (20) Total</b>				<b>\$99,392</b>	<b>\$0</b>
<b>21</b>		<b>INDUSTRIAL LANE SUBSTATION - U</b>					
	1	SUBSTATION 900 INDUSTRIAL LANE WATERLOO WI 53594	1997	1	0	\$788,899	\$0
		Property in the open					\$27,522
		<b>INDUSTRIAL LANE SUBSTATION - U (21) Total</b>				<b>\$788,899</b>	<b>\$27,522</b>

# STATEMENT OF VALUES

## MUNICIPAL PROPERTY INSURANCE COMPANY

Coverage Amount - 53,712,633

Site	Bldg	Description	Year Built	Floors	Square Footage	Building CRN	Content CRN
<b>22 UTILITIES ADMINISTRATION - U</b>							
	1	ADMINISTRATION/STORAGE BUILDING 575 COMMERCIAL AVENUE WATERLOO WI 53594	2003	1	31,059	\$4,864,209	\$475,051
		Property in the open					\$107,081
		<b>UTILITIES ADMINISTRATION - U (22) Total</b>				<b>\$4,864,209</b>	<b>\$582,132</b>
<b>23 STREETOR LANE LIFT STATION - U</b>							
	1	PITO - LIFT STATION STREETOR LANE WATERLOO WI 53594	0	1	300	\$192,433	\$0
		<b>STREETOR LANE LIFT STATION - U (23) Total</b>				<b>\$192,433</b>	<b>\$0</b>
<b>24 LEXINGTON WAY LIFT STATION - U</b>							
	1	PITO - LIFT STATION LEXINGTON WAY WATERLOO WI 53594	0	1	300	\$244,915	\$0
		<b>LEXINGTON WAY LIFT STATION - U (24) Total</b>				<b>\$244,915</b>	<b>\$0</b>
<b>25 FIREMAN'S PARK LIFT STATION - C</b>							
	1	SEWER LIFT STATION FIREMANS PARK WATERLOO WI 53594	0	1	225	\$142,625	\$0
		<b>FIREMAN'S PARK LIFT STATION - C (25) Total</b>				<b>\$142,625</b>	<b>\$0</b>
<b>26 Various</b>							
		Property in the open					\$194,996
		<b>Various (26) Total</b>				<b>\$0</b>	<b>\$194,996</b>
<b>27 REGIONAL TRAILHEAD - P</b>							
	1	TRAILHEAD 760 MCKAY WAY WATERLOO WI 53594	2013	1	1,950	\$666,998	\$25,925
		Property in the open					\$34,765
		<b>REGIONAL TRAILHEAD - P (27) Total</b>				<b>\$666,998</b>	<b>\$60,690</b>
<b>28 DEYOUNG LIFT STATION - U</b>							
	1	SEWER LIFT STATION [ADD01] WATERLOO WI 53594	0	1	300	\$190,984	\$0
		<b>DEYOUNG LIFT STATION - U (28) Total</b>				<b>\$190,984</b>	<b>\$0</b>

# STATEMENT OF VALUES

## MUNICIPAL PROPERTY INSURANCE COMPANY

Coverage Amount - 53,712,633

Site	Bldg	Description	Year Built	Floors	Square Footage	Building CRN	Content CRN
<b>29</b>		<b><i>Hwy O Substation - U</i></b>					
	1	Hwy O Substation - U N8896 Cty Highway O Waterloo WI 53594	0	0	0	\$1,660,000	\$1,340,000
		<b>Hwy O Substation - U (29) Total</b>				<b>\$1,660,000</b>	<b>\$1,340,000</b>
<b>Building Subtotal</b>							<b>\$45,915,321</b>
<b>Contents Subtotal</b>							<b>\$5,781,231</b>
<b>Property in the Open Subtotal</b>							<b>\$2,016,081</b>
<b>Building, Contents and PITO Total</b>							<b>\$53,712,633</b>

# PROPERTY IN THE OPEN

## MUNICIPAL PROPERTY INSURANCE COMPANY

Site	Description	Quantity	New Cost of Replacement
<b>1</b>	<b>DEPARTMENT OF PUBLIC WORKS</b>		
	FENCING, 6 FT CLF		\$14,597
	SAFETY BOLLARD		\$2,674
	SECURITY GATE		\$4,568
	SIGNAGE		\$3,788
	<b>DEPARTMENT OF PUBLIC WORKS (1) TOTAL</b>		<b>\$25,628</b>
<b>5</b>	<b>MUNICIPAL BUILDING</b>		
	BENCH		\$2,229
	COMMUNICATION TOWER		\$64,182
	FLAGPOLE		\$3,788
	MISCELLANEOUS		\$3,677
	OUTDOOR LIGHTING		\$4,680
	SECURITY GATE		\$1,226
	TRANSFORMER		\$25,071
	TRASH ENCLOSURE		\$4,123
	<b>MUNICIPAL BUILDING (5) TOTAL</b>		<b>\$108,975</b>
<b>6</b>	<b>PITO - Various</b>		
	Sirens		\$44,571
	<b>PITO - Various (6) TOTAL</b>		<b>\$44,571</b>
<b>8</b>	<b>KARL JUNGINGER MEMORIAL LIBRARY</b>		
	BENCH		\$2,229
	FLAGPOLE		\$2,563
	MISCELLANEOUS		\$2,674
	OUTDOOR LIGHTING		\$5,794
	OUTDOOR LIGHTING		\$33,094
	SIGNAGE, ELECTRIC		\$12,703
	SIGNAGE, STONE		\$9,583
	<b>KARL JUNGINGER MEMORIAL LIBRARY (8) TOTAL</b>		<b>\$68,639</b>
<b>9</b>	<b>FIRE STATION-HEADQUARTERS</b>		
	BOLLARDS		\$4,457
	TRANSFORMER		\$5,571
	COMMUNICATION TOWER		\$16,157
	FENCING, 6 FT CLF W/ PRIVACY		\$2,340
	FLAGPOLE		\$3,231
	MISCELLANEOUS		\$2,451
	OUTDOOR LIGHTING		\$26,074
	SATELLITE DISH		\$9,248
	SECURITY GATE		\$2,117
	SIGNAGE		\$3,566
	<b>FIRE STATION-HEADQUARTERS (9) TOTAL</b>		<b>\$75,213</b>
<b>10</b>	<b>FIREMAN'S PARK - P</b>		
	BACKSTOP		\$12,480

# PROPERTY IN THE OPEN

## MUNICIPAL PROPERTY INSURANCE COMPANY

Site	Description	Quantity	New Cost of Replacement
	GOAL, BASKETBALL		\$4,903
	GOAL, DISC GOLF		\$5,014
	MISCELLANEOUS		\$9,806
	OUTDOOR LIGHTING		\$42,899
	OUTDOOR LIGHTING		\$104,295
	OUTDOOR LIGHTING (ATHLETIC FIELD)		\$264,303
	PLAYGROUND EQUIPMENT		\$71,536
	SCOREBOARD - Baseball		\$25,000
	Scoreboard - Softball x2		\$25,000
	SIGNAGE		\$18,720
	Baseball Fencing 10 ft		\$45,000
	Volleyball Court		\$8,000
	BATTING CAGE		\$8,691
	BENCH		\$14,151
	BLEACHERS, ALUMINUM		\$15,823
	BLEACHERS, WOOD		\$1,894
	BRIDGE, PEDESTRIAN		\$435,343
	DECORATIVE ENTRANCE		\$75,770
	FENCING, SPLIT RAIL		\$6,463
	<b>FIREMAN'S PARK - P (10) TOTAL</b>		<b>\$1,195,090</b>
<b>11</b>	<b><i>SOUTH MONROE SUBSTATION - U</i></b>		
	FENCING, 6 FT CLF		\$4,568
	SECURITY GATE		\$3,566
	<b>SOUTH MONROE SUBSTATION - U (11) TOTAL</b>		<b>\$8,134</b>
<b>12</b>	<b><i>WEST MADISON SUBSTATION - U</i></b>		
	FENCING, 6 FT CLF		\$6,017
	SECURITY GATE		\$2,006
	<b>WEST MADISON SUBSTATION - U (12) TOTAL</b>		<b>\$8,023</b>
<b>14</b>	<b><i>WATER STORAGE TANK - U</i></b>		
	TELECOM SHED		\$2,674
	<b>WATER STORAGE TANK - U (14) TOTAL</b>		<b>\$2,674</b>
<b>15</b>	<b><i>WELL HOUSE 4 - U</i></b>		
	TRANSFORMER		\$18,720
	<b>WELL HOUSE 4 - U (15) TOTAL</b>		<b>\$18,720</b>
<b>16</b>	<b><i>WELL HOUSE 2 - U</i></b>		
	TRANSFORMER		\$18,720
	<b>WELL HOUSE 2 - U (16) TOTAL</b>		<b>\$18,720</b>
<b>18</b>	<b><i>WASTEWATER TREATMENT PLANT - U</i></b>		
	FENCING, 6 FT CLF W/ 3-BARB		\$16,045
	FENCING, 7 FT CLF		\$15,823
	OUTDOOR LIGHTING		\$7,466

# PROPERTY IN THE OPEN

## MUNICIPAL PROPERTY INSURANCE COMPANY

Site	Description	Quantity	New Cost of Replacement
	SAFETY BOLLARD		\$5,348
	SECURITY GATE		\$29,528
	SIGNAGE		\$3,120
	<b>WASTEWATER TREATMENT PLANT - U (18) TOTAL</b>		<b>\$77,330</b>
<b>21</b>	<b><i>INDUSTRIAL LANE SUBSTATION - U</i></b>		
	FENCING, 8 FT CLF W/ 3-BARB		\$8,134
	SECURITY GATE		\$2,006
	YARD STORAGE		\$17,383
	<b>INDUSTRIAL LANE SUBSTATION - U (21) TOTAL</b>		<b>\$27,522</b>
<b>22</b>	<b><i>UTILITIES ADMINISTRATION - U</i></b>		
	COMMUNICATION TOWER		\$16,157
	FLAGPOLE		\$3,788
	OUTDOOR LIGHTING		\$22,062
	SAFETY BOLLARD		\$669
	SIGNAGE		\$9,471
	SOLAR ARRAY		\$29,862
	TRANSFORMER		\$25,071
	<b>UTILITIES ADMINISTRATION - U (22) TOTAL</b>		<b>\$107,081</b>
<b>26</b>	<b><i>Various</i></b>		
	PITO - Utility Poles		\$194,996
	<b>Various (26) TOTAL</b>		<b>\$194,996</b>
<b>27</b>	<b><i>REGIONAL TRAILHEAD - P</i></b>		
	MONUMENT		\$13,371
	OUTDOOR LIGHTING		\$12,034
	PICNIC TABLE		\$2,229
	SIGNAGE		\$5,348
	TRASH RECEPTACLE		\$1,783
	<b>REGIONAL TRAILHEAD - P (27) TOTAL</b>		<b>\$34,765</b>
<b>PROPERTY IN THE OPEN TOTAL</b>			<b>\$2,016,081</b>

# CONTRACTOR'S EQUIPMENT

## MUNICIPAL PROPERTY INSURANCE COMPANY

Description	RCN Subject
1 BOBCAT 48" PALLET FORKS. SN:N/A - D	\$530
1 BOBCAT 5595 SKID-STEER LOADER, - D	\$43,440
1 BOBCAT 68" ANGE BROOM. - D	\$3,672
1 BOBCAT 74" BUCKET - D	\$796
1984 Toro SandPro & Accessories - P	\$3,000
1988 Miller Roghneck2E Portable Arc Welder & Generator - D	\$1,546
1993 Case Trencher - U	\$10,200
1994 John Deere 770286Wheel Tractor 2555 - D	\$36,410
1995 Pole Utility Trailer - D	\$1,658
2000 Bigo Car Hauler Trailer - D	\$4,080
2000 Wacker RD11A HydrostaticVibratory Roller - D	\$6,670
2001 John Deere 310SGWheel Loader Backhoe - D	\$122,296
2004 Karavan Utility Trailer - U	\$2,239
2005 Universal 12-43L12' Pusher Plow (Truck 5)	\$4,413
2006 ELGIN PELICAN STREET SWEEPER - D	\$173,499
2007 Graco 3900Line Lazwer - D	\$1,847
2008 Bandit 200C81Wood Chipper 200XP - D	\$42,678
2008 John Deere 4x2 TXGator - D	\$6,379
2008 Stihl TS400Cut Off Saw - D	\$918
2009 EJ Metals ATV Trailer - U	\$7,548
2009 Mac Lander Trailer	\$3,652
2009 Polaris Ranger 700 EFI4x4 - F	\$11,113
2009 Sweenson SAD-6ssBH1240Tailgate Sander (Truck 1) - D	\$8,971
2009 Universal BH124012' Plow (Truck 1) - U	\$4,521
2011 Boss Super Duty9' Snow Plow (Truck 6) - U	\$3,591
2011 John Deere 4x2 TXGator - D	\$7,183
2011 Land Pride 6293Flail Mower - D	\$3,850
2012 Deere Wheel Loader 544K - D	\$135,150
2013 Berti 101730Flail Mower - D	\$7,694
2013 John Deere X750Tractor 101713 & Hard Cab X700 #101711 & 60 HC Deck X700 #101714 - D	\$15,068
2013 John Deere X750Tractor 101722 & 60 HC Deck X700101723 - D	\$11,425
2013 Polaris Ranger 900 XP 4x4 - F	\$12,240
2015 John Deere X758Tractor with 60" Mower Deck - U	\$14,280
2015 Swenson Tailgate Spreader (TRK 5) - D	\$3,490
2015 Universal Plow (TRK 5) - D	\$4,551
2016 Tailgate Spreader TRK7 - D	\$3,060
2017 Hot Pressure Washer (Beaver) - D	\$7,140
2017 John Deere JDX48546" Snowthrower for X485 - D	\$2,077
2017 Kage Pusher Plow - D	\$6,120
2017 Miller Matic Mig Welder (250) - D	\$2,856
2017 Scag SCZ61VCheetah w/ROPS 61" Deck 34 HP Kohler Engine w Collection System - D	\$12,826
2017 Swenson UPMS-966-RFDDAUSSTRReverse Flight Under-Tailgate Spreader (Truck 5) - D	\$3,488
2017 Universal MP41-R12-CT-10GAFull Moldboard Trip Reversible Plow (Truck 5) - Plow	\$4,551
2017 Yale Shop Post Crane - D	\$3,060
2019 Bobcat Stumpgrinder - D	\$7,000
2019 JD 1025R Tractor w/ Cab, Front Hitch & Broom - D	\$21,481
2020 JOHN DEERE 35G COMPACT EXCAVATOR, - U	\$52,626
2020 Swenson Tailgate Spreader (Truck 2) - D	\$2,565
2020 Universal BH124012 Plow (Truck 2) - D	\$3,118
2021 Scag Mower SCZII61V38 - D	\$10,933
3 Point Sprayer - D	\$2,380

# CONTRACTOR'S EQUIPMENT MUNICIPAL PROPERTY INSURANCE COMPANY

Description	RCN Subject
Air Compressor Bld 1 Quincy 325 - D	\$2,958
Air Compressor Bld 3 Quincy 325 - D	\$2,958
Cement Mixer (Harbor Freight) - D	\$2,380
Leaf Collection System SCAG/JD/AG FAB - D	\$2,380
Stihl Chain Saw MS261 - D	\$255
Stihl Chain Saw MS461 - D	\$255
Stihl Power Pruner 133 - D	\$510
unk Allied 8700CHo Pac Compactor - U	\$5,406
unk Allied AS370Hydraulic Breaker (Hammer) - U	\$13,260
unk Atlas Copco XAS90-185CFMAir Compressor - U	\$18,870
unk Mueller 3W.2002.1Portable Pump - U	\$4,692
unk Onan unkPortable Generator Set - U	\$8,160
<b>CONTRACTOR'S EQUIPMENT TOTAL</b>	<b>\$606,099</b>



# Cyber Liability

# Cyber Chubb Notes

**Changes within quote other than premium and retention (all highlighted on quote):**

Waiting period for Business Interruption increased to 12hrs

Waiting period for Contingent Business Interruption increased to 12hrs

Addition of below exclusions:

**PF-48161 Specified Incident Exclusion – For Government Shutdown**

**FILL:** the application or enforcement of any law, rule, regulation, ordinance, code, governmental directive, standard, or legal or administrative restriction of any kind mandating the shutdown of: a. an Insured's Computer System; b. a Shared Computer System; c. any Internet infrastructure or telecommunications infrastructure, which is owned, operated, or controlled by a third party with whom an Insured does not have a direct written contract; or d. any Internet access or telecommunications service of any Domain Name System ("DNS") Top-Level Domain, DNS Root Zone, Tier 1 Internet Service Provider in the provider's capacity as such, or Tier 1 Telecommunications Provider in the provider's capacity as such. However, this exclusion shall not apply a Claim or Incident resulting from a Cyber Incident otherwise covered under this Policy.

**Removing:**

**PF-48153 Optional Extended Reporting Period Item 7 Amended Endorsement**

**Named insured: City of Waterloo**

**Chubb Cyber Enterprise Risk Management Policy**

**Option: 1**

<b>Maximum Single Limit of Insurance</b>	<b>\$1,000,000</b>	<b>Premium</b>	<b>\$5,635</b>
<b>Maximum Policy Aggregate Limit of Insurance</b>	<b>\$1,000,000</b>	<b>Surcharges/Assessments/Taxes</b>	<b>\$0.00</b>

**Policy Period Premium** **\$5,635.00**

Optional Extended Reporting Period: 12 months for 100% of last annual premium

**First Party Insuring Agreements**

Check if Included	Insuring Agreement	Limit of Insurance Each Incident/Aggregate	Retention/Waiting Period Each Incident	Cyber Incident Response Coach Retention
<input checked="" type="checkbox"/>	Cyber Incident Response Fund			
	Cyber Incident Response Team	\$1,000,000/\$1,000,000	\$3,500	\$0
	Non-Panel Response Provider	\$500,000/\$500,000	\$3,500	\$3,500
<input checked="" type="checkbox"/>	Business Interruption Loss and Extra Expense	\$1,000,000/\$1,000,000	\$3,500/12 Hours	<u>N/A</u>
<input checked="" type="checkbox"/>	Contingent Business Interruption Loss and Extra Expense			
	Unscheduled Providers	\$150,000/\$150,000	\$3,500/12 Hours	<u>N/A</u>
	Scheduled Providers	<u>N/A</u>	<u>N/A</u>	<u>N/A</u>
<input checked="" type="checkbox"/>	Digital Data Recovery	\$1,000,000/\$1,000,000	\$3,500	<u>N/A</u>
<input checked="" type="checkbox"/>	Network Extortion	\$1,000,000/\$1,000,000	\$3,500	<u>N/A</u>

**Third Party Liability Insuring Agreements**

Check if Included	Insuring Agreement	Limit of Insurance Each Claim/Aggregate	Retention Each Claim	Retroactive Date	Pending or Prior Proceedings Date
<input checked="" type="checkbox"/>	Cyber Privacy, Network and Security Liability	\$1,000,000/\$1,000,000	\$3,500	01-01-1925	01-01-2021
	Payment Card Loss	\$1,000,000/\$1,000,000	\$3,500	01-01-1925	01-01-2021
	Regulatory Proceedings	\$1,000,000/\$1,000,000	\$3,500	01-01-1925	01-01-2021
<input checked="" type="checkbox"/>	Electronic, Social, and Printed Media Liability	\$1,000,000/\$1,000,000	\$3,500	01-01-1925	01-01-2021

**Other Notes about this option**

**Subjectivities**

Chubb hereby indicates the coverage described below. However, any obligations the Insurer may have under this indication are conditioned upon each of the following conditions having first been met.

Please Note the Following for the Terrorism Risk Insurance Act:

Coverage for acts of terrorism is included in your policy. The portion of your annual premium that is attributable to coverage for

acts of terrorism is \$0, and does not include any charges for the portion of losses covered by the United States government under the Act.

The Following Notices will be added to the basic contract(s)

Title	Form Number
Chubb Producer Compensation Practices & Policies	ALL-20887a (03/16)
Policyholder Notice Cyber Services for Loss Mitigation	PF-48260 (10/16)
Policyholder Notice Cyber Services for Incident Response	PF-48259 (02/19)
U.S. Treasury Department's Office of Foreign Assets Control ("OFAC") Advisory Notice to Policyholders	PF-17914a (04/16)
Trade or Economic Sanctions Endorsement	PF-46422 (07/15)
Policyholder Disclosure Notice Of Terrorism Insurance Coverage	TR-19606e (08/20)
Cap On Losses From Certified Acts Of Terrorism	PF-45354 (02/19)
Signatures	CC-1k11j (03/21)
Important Notice - Wisconsin	ALL-38969 (08/12)
Wisconsin Notice to Policyholders	ALL-5X51a (02/06)

The Following Endorsement(s) will added to the basic contract(s)

Title	Form Number
Additional Insured – Blanket Pursuant to a Contract – Cyber ERM	PF-48155 (02/19)
Duty To Defend A Regulatory Proceeding	PF-49445 (02/19)
Specified Incident Exclusion	PF-48161 (02/19)
Specified Incident: alleging, based upon, arising out of, or attributable to any government-mandated restriction of operations, closure, or shutdown, of (i) any entity or person operating a Computer System or (ii) any Computer System; provided, however, this exclusion shall not apply to a government-mandated restriction, closure, or shutdown of the Insured's Computer System, in response to an otherwise covered Malicious Computer Act solely against the Insured's Computer System.	
Amendatory Endorsement – Wisconsin	PF-48333(02/19)

## Conditions of this Indication

This indication will remain valid until 01-01-2022.

If between the date of this Indication and the Effective Date of the policy there is a significant adverse change in the condition of this Applicant, or an occurrence of an event, or other circumstances which could substantially change the underwriting evaluation of the Applicant, then, at the Insurer's option, this indication may be withdrawn by written notice thereof to Applicant. The Insurer also reserves the right to modify the final terms and conditions upon review of the completed application and any other information requested by the underwriter herein. If such material change in the risk is discovered after binding, the insurance coverage will be void ab initio ("from the beginning").

FOR POLICIES EFFECTIVE JULY 21, 2011 AND SUBSEQUENT, WE REQUIRE THE PRODUCER TO PROVIDE THE "HOME STATE" AS DEFINED IN THE NONADMITTED AND REINSURANCE REFORM ACT OF 2010 (NRRA) UPON THE BINDING OF THIS PLACEMENT. IF THE STATE SET FORTH IN THE ABOVE-REFERENCED INSURED ADDRESS IS THE HOME STATE OF THE INSURED, NO ACTION IS REQUIRED. HOWEVER, IF THE HOME STATE OF THE INSURED IS OTHER THAN THAT SET FORTH IN THE INSURED ADDRESS, YOU MUST NOTIFY US IN WRITING PRIOR TO THE BINDING OF THIS PLACEMENT.

Note: If the Insuring Company noted above is Chubb Custom Insurance Company, Westchester Surplus Lines Insurance Company or Illinois Union Insurance Company, then this insurance is issued pursuant to the state Surplus Lines laws that the insured is domiciled. Persons insured by Surplus Lines carriers do not have the protection of the above captioned state's Guaranty Act to the extent of any right of recovery for the obligation of an insolvent unlicensed insurer.

Any applicable taxes, surcharges or countersignature fees, etc., are in addition to the above indicated figures. Your office is responsible for making State Surplus Lines Filings and complying with all applicable laws.

Sincerely,

Jenny Garate

Chubb. Insured.<sup>SM</sup>



# Premier Services Customized For You



# REBOUND

We protect those who protect us

Every day, public safety workers get hurt on and off the job.





When that happens, Rebound is here to help.

We guide workers through a complex healthcare system to heal more quickly, which saves time and money for all stakeholders.



## Your employees get better. Faster.

### Benefits to you

-  We seamlessly integrate into your workers compensation process without adding work or eliminating jobs. It's truly a no-hassle process.
-  Rebound's medical providers understand the physical challenges of your workforce, and the vast majority are sports medicine trained.
-  Rebound's Orthopedic Patient Navigators help your injured employee select the best provider in our network based on location, history and needs.
-  Our advocates guide your employees through the entire process, from the moment we take their injury call until their ready-for-duty orders are signed.

*"Rebound has literally done everything they said they would do, as well as go above and beyond. Budgets are getting hit hard, and injuries are a big part of that. When you have Rebound in your corner, helping you get people back to the job faster, that is huge for us from a daily staffing perspective and a budgetary standpoint."*

**Battalion Chief  
Robbie Franks  
Memphis Fire Department**



### Contact us

[hello@justrebound.com](mailto:hello@justrebound.com)  
[justrebound.com](http://justrebound.com)





+



## **Nurse Triage & Telehealth**

---

League of Wisconsin Municipalities Mutual Insurance is proud to partner with CorVel as our nurse triage and telehealth partner. CorVel's proactive healthcare solution connects injured workers to medical services ensuring they feel cared for in the event of a workplace injury.

### **Nurse Triage**

At the time of a workplace injury, employees can call and speak with a registered nurse through CorVel's 24/7 nurse hotline who will evaluate the injury to determine immediate medical needs. By addressing the injury when it first occurs, CorVel can provide quick and timely care for your employees.

### **Telehealth**

CorVel's nurses are trained to provide an initial assessment and will provide immediate referral to medical care when needed. Nurses may also refer to telehealth as appropriate at the option of the employee. This feature connects the injured worker to a physician immediately via a computer, tablet, or phone. The CorVel nurse will email a link with instructions directly to the injured worker. The CorVel nurse will stay on the telephone with the injured worker until they are connected to the online visit.

### **Advantages of Telehealth**

For many workplace injuries, immediate treatment can be received through a virtual visit with a doctor eliminating the need for scheduling and attending an in-person appointment. No driving to a doctor's office, missed appointments, or delays in waiting rooms. With the advent of new technologies, many welcome the convenience of a virtual visit with a doctor and the added expediency of prescriptions and physical therapy scheduling. By connecting our employees with appropriate, quality care, it can help prevent a minor injury from becoming a complicated injury and focus on your employee's wellness.

### **About Telehealth Physicians**

CorVel has contracted with dedicated physicians who average 15 years in primary and urgent care experience, and are US Board Certified, licensed, and credentialed.

### **Rebound**

For our members that currently utilize our Rebound injury management program, you can continue to contact Rebound directly as you have been doing for any musculoskeletal injuries (knee, shoulder, back, hip, etc.). Also, the nurses at CorVel can provide a referral to Rebound for those injuries as appropriate. The services are designed to work together to achieve the best outcome.

### **Reporting a Claim**

For any work related injury that goes through the 24/7 nurse hotline, CorVel will automatically send the first notice of injury to United Heartland for claim handling. If you chose not to use CorVel, you will need to submit your claim to United Heartland as previously done.

***Better injury management helps your employees and your bottom line.***



# 24/7 Work Injury Nurse Line



Immediately following a workplace injury, call to speak with a registered nurse who will evaluate your incident and determine care. Our nurses specialize in occupational injuries and will connect you with the quality care you need.

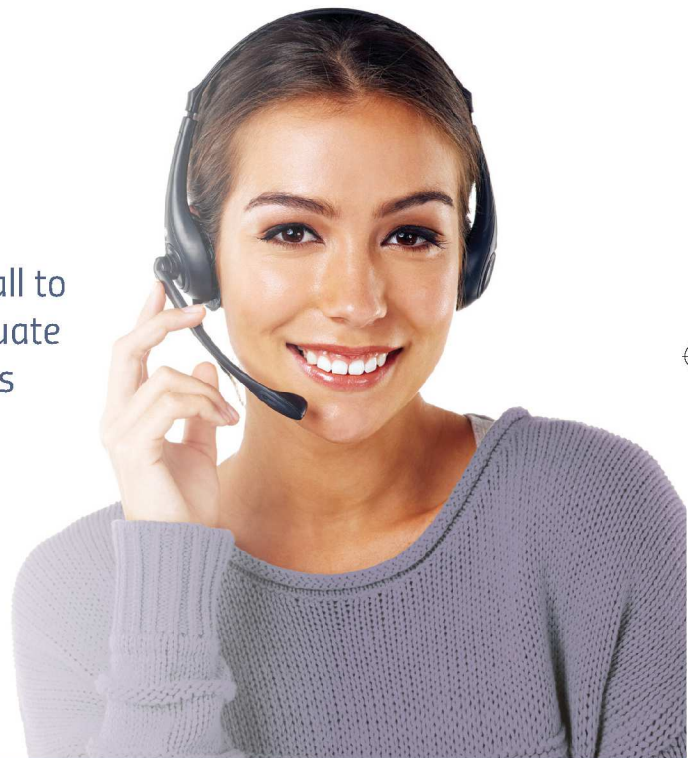

**(855) 438-4577**

**Call 911 for Medical Emergencies**

# Human Resources & Pre-Loss Legal Services



## ***Human Resources Legal Services***

The League of Wisconsin Municipalities Mutual Insurance (LWMMI) has partnered with our colleagues at the Stafford Rosenbaum law firm to provide the following human resources legal services at no cost to insured members:

- *HR Hotline: Phone assistance with HR-related issues.*
- *Talent Management: Support with recruitment, hiring, background screening, onboarding, performance management, disciplinary counseling, and termination management.*
- *Employment Law Compliance: WI and Federal Fair Employment, Wage & Hour, Safety, FMLA, I9 and more.*
- *Documents: Development/review of job descriptions, handbooks, policies, procedures, and forms customized for the municipality.*
- *Workplace Training: Supervisors and/or employees related to compliance and HR-related topics.*
- *Workplace investigations.*

## ***Pre-loss Legal Services***

Has something happened in your community recently where you need legal advice? Stafford Rosenbaum offers insured members no cost pre-loss legal services:

- *Land use, zoning, permits*
  - *Conflicts of interest*
  - *Tax assessments*
  - *Open meetings and public records*
  - *Contractual issues*
- ...and many more.*

Contact:

Ted Waskowski—Partner

twaskowski@staffordlaw.com

(608) 256-2613





# PROTECT YOUR AGENCY, MINIMIZE YOUR RISK

Special Public Safety Savings Program for  
League of Wisconsin Municipalities Mutual  
Insurance (LWMMI) Members

**Lexipol**, the most trusted name in policy management and integrated policy training, is offering our LWMMI partners a special opportunity. For a limited time, LWMMI members are eligible to receive:

- 10% discount on current market rate subscription when agencies subscribe to either Lexipol's Wisconsin Law Enforcement or Fire policies and training
- Up to \$2,500 funding per municipality for the Lexipol policy solutions platform
- Customized implementation options to fit your agency to help you get your manual up-and-running faster (Please inquire to find out which implementation options are best for your agency.)

Protect your community with policies that are continuously updated as state and federal laws, and best practices change – and training to ensure your policies are known and understood.

For more information, to request sample policies, or to schedule a demo of the Lexipol Policy Solutions, please contact Brandi Galloway at 469-553-0639 or [bgalloway@lexipol.com](mailto:bgalloway@lexipol.com).



"In every tragedy there is always a proximate cause: the event that instantly preceded the tragedy. But if you go back in time and look for the root cause, all too often it comes down to a lack of good policy and a lack of good training."

**Gordon Graham**  
Co-founder, Lexipol

"The average agency takes 2 to 5 years to complete the accreditation process. We did it in about 18 months, and one of the big reasons was because we had many of the policies in place."

- Chief Tim Styka, Menasha Police Department

"There is no way we could have built what we have on our own, and there is no way we could have continued to maintain it."

- Chief Jon Cohn, Greenfield Fire



# LWMMI UNIVERSITY ADMINISTRATOR FEATURE OVERVIEW

## The Benefits of the LWMMI University

The League of Wisconsin Municipalities (LWMMI) has partnered with LocalGovU to deliver online training to our members at no cost. Online training improves the safety and effectiveness of your organization and personnel, while contributing to successful professional development.

Employees can conveniently access hundreds of e-learning courses 24/7, allowing them to balance their work schedules while completing practical and informative self-directed training at their own pace.

Members can choose to train by topic or can select more specific courses by profession.

## Fulfill Training Requirements

For law enforcement, the LWMMI Police University can fulfill 8 of the 24 hours of annual training requirements with department-level approval.

For Water and Wastewater, LWMMI University courses can be used to fulfill the required hours of annual training requirements. Wastewater professionals will need to submit their certificate of course completion directly to the Department of Natural Resources for training approval.

### COURSE LIBRARY

- Compliance (HR/Safety)
- EEOC and Employment Law
- Emergency Medical Services
- Equipment Safety
- Financial Management
- General Safety
- Health and Wellness
- HR Development
- Information Technology
- Law Enforcement
- Leadership Development
- Professional Development
- Risk Management
- Roadway and Highway
- Schools and Educational
- Transit and Fleet Operations
- Water and Wastewater



# Learning Management System Admin Features

## Assignments

Schedule online training to align with internal training calendars, control access to online courses and material and document offline training.

## Groups

Build and manage custom groups for personnel, dividing them by certification level, rank, shift or other tailored options.

## Notification Manager

Activate action-based, pre-scheduled, recurring and other notifications targeted to specific groups, organizations and job titles.

## Reports

Create recurring or on-demand reports for tracking compliance of personnel assignments and credentials. Pull reports for members, groups and courses, and export training records based on rank, division, shift, course or assignment.

## Individual User Access

Using the dashboard, members can easily see which courses they are assigned, and download certificates of completion.

## Custom Roles

Manage personnel access seamlessly with five user roles, letting members see and access only what they need.

## Custom Homepage

Customize your homepage with your logo, important information and featured courses.

## Training Calendar

Visually manage several features by date, including assignments, credentials, training events and more through a centralized training calendar with both member and administrator views.

# Admin Features and Users Personal Dashboard

## Admin Features

- Add members and organize into groups
- Assign group admins or user-specific roles
- Create quick assignments or bundle courses into learning plans
- Track training and compliance through ad hoc or recurring reports
- Manage and customize training and assignment notifications
- Assign and manage course credits from online and in person training
- Highlight featured courses or hide select courses from view

## Individual User Dashboard

- Track assignments and training activity
- Download certificates and personal training reports
- Access virtual training calendar
- Receive and manage personal notifications

## Dedicated Customer Support

Support from LocalGovU is available from Monday through Friday, 8:00 a.m. – 5:00 p.m. CST. If you have questions or need assistance, you can contact customer support directly at 866.845.8887 or [LLWMI@localgovu.com](mailto:LLWMI@localgovu.com).

## Mo Hansen

---

**From:** Gabe Haberkorn  
**Sent:** Monday, December 13, 2021 11:36 AM  
**To:** Mo Hansen  
**Subject:** Playground Equipment Quotes and Plans  
**Attachments:** WRT - 11-03-2021 PROPOSAL 142-146557-1.pdf; Lower FP - 11-03-2021 PROPOSAL 142-146564-1.pdf; Upper FP - 11-03-2021 PROPOSAL 142-146560-1.pdf

Mo,

Here is the documentation for the proposed Playground work. Total quote was for \$100,726.

WRT - \$24,595  
Lower Park – \$44,153  
Upper Park - \$31,978

**Gabe Haberkorn**  
**City of Waterloo – Parks Coordinator**  
**136 N. Monroe Street**  
**Waterloo, WI 53594**

**Office:** (920) 478-3025  
**E-Mail:** [parks@waterloowi.us](mailto:parks@waterloowi.us)  
**Website:** <http://www.waterloowi.us/>





**COLOR KEY**

- BURGUNDY
- GOLD
- GRANITE
- GRAY
- YELLOW
- B GRAY/BLACK





October 29, 2021

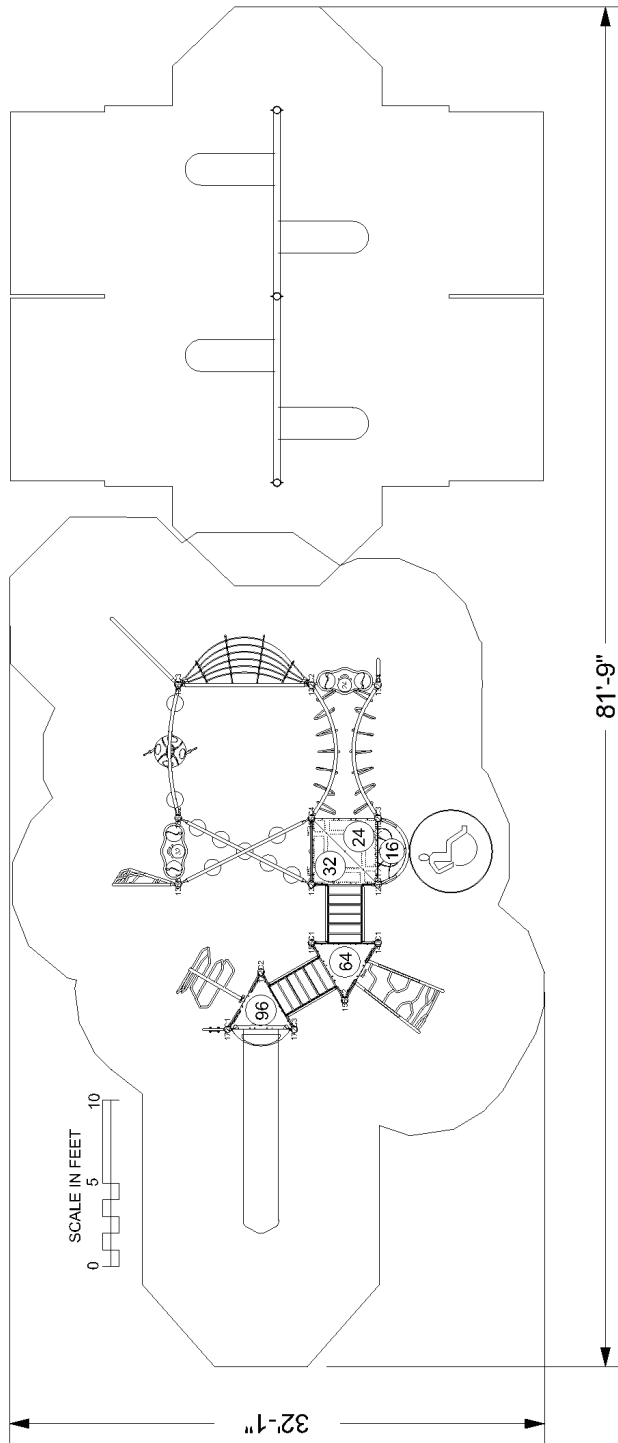

**INFORMATION**  
 MINIMUM FALL ZONE  
 SURFACED WITH  
 RESILIENT MATERIAL  
 AREA  
 1986 SQ.FT.  
PERIMETER  
 296 FT.  
STRUCTURE SIZE  
 32' 1" x 81' 9"

STRUCTURE IS DESIGNED  
 FOR CHILDREN AGES:  
 6-23 MONTH OLDS  
 2-5 YEAR OLDS  
 5-12 YEAR OLDS  
 13 + YEAR OLDS



The play components identified in this plan are IPEMA certified. The use and layout of these components conform to the requirements of ASTM F1487. To verify product certification, visit www.ipema.org

The space requirements shown here are to ASTM standards. Requirements for other standards may be different.

The use and layout of play components identified in this plan conform to the CPSC guidelines. U.S. CPSC recommends the separation of age groups in playground layouts.

**ADA ACCESSIBILITY GUIDELINE (ADAAG CONFORMANCE)**

NUMBER OF PLAY EVENTS:	16
NUMBER OF ELEVATED PLAY EVENTS:	7
NUMBER OF ELEVATED PLAY EVENTS ACCESSIBLE BY RAMP:	PROVIDED 0
NUMBER OF ELEVATED PLAY EVENTS ACCESSIBLE BY TRANSFER SYSTEM:	PROVIDED 6
NUMBER OF ELEVATED PLAY EVENTS ACCESSIBLE BY RAMP OR TRANSFER SYSTEM:	PROVIDED 11
NUMBER OF GROUND LEVEL PLAY EVENTS:	PROVIDED 4
NUMBER OF TYPES OF GROUND LEVEL PLAY EVENTS:	PROVIDED 2
RECD:	0
RECD:	4
RECD:	2
RECD:	2

**WARNING!**

ACCESSIBLE SAFETY SURFACING MATERIAL IS REQUIRED BENEATH AND AROUND THIS EQUIPMENT.  
 FOR SLIDE FALL ZONE SURFACING AREA SEE CPSC's Handbook for Public Playground Safety.  
 PLATFORM HEIGHTS ARE IN INCHES ABOVE RESILIENT MATERIAL.





Office (800) 775-8937  
 Fax (608) 423-7655

260 W. Main Street  
 Cambridge, WI 53523

info@leerecreation.com  
 www.leerecreation.com

## Quotation

DATE: Nov. 3, 2021

TO: Gabe Haberkorn  
 Village of Waterloo  
 136 N. Monroe St.  
 Waterloo, WI 53594

FROM: Jeff Thompson

RE: Playground Proposal #142-146564-1  
**Waterloo Fireman's Park – Lower Playground**

### BURKE "Play That Moves You"

Proposal #142-146564-1

18 Play Events for an Estimated 78 users – ages 5-12 years  
 Minimum area needed: 36' x 84'

NUIN-2977	Modular Playstructure Includes:	\$41,335.00
	<i>All 4 Play Fall Savings</i>	(\$14,054.00)
<b>DECKS:</b>	2-Triangle, 1-Split Square, Crescent Platform	
<b>CLIMBERS:</b>	Verto Climber, Wild Web, Power Peak, Taktiks Bow Climber, Podstep Climber, Verve Climber, Beta Climber	
<b>SLIDES:</b>	Velo XL Straight Slide @ 96" Deck Ht.	
<b>UPPER BODY EVENTS:</b>	2-Straight Overhead	
<b>BALANCE:</b>	2- Dynamic Pads	
<b>PLAY ACTIVITY PANEL:</b>	Rain Crescent Panel	
1-#SWING	Single Post Swing Assembly	<u>\$ 2,772.00</u>
	Includes: 2 Swing Bays with 4 Belt Seats	
	Subtotal Equipment	\$30,053.00
	Assembly/Installation	\$11,000.00
	60 – 4' Border Timbers	\$ 2,400.00
	Freight	<u>\$ 700.00</u>
	<b>TOTAL</b>	<b>\$44,153.00</b>

Quote accepted by: \_\_\_\_\_ Date: \_\_\_\_\_

- TERMS: Net 20
- Site Preparation, Surfacing & Placement of Surfacing & Site Restoration is the responsibility of the Customer
- Lead-Time: 8-10 weeks upon receipt of order
- Quote effective: **Good through 11-30-2021 (Sale ends 12-31-21)**





**COLOR KEY**

- BURGUNDY
- CHARCOAL
- YELLOW
- GRANITE
- BLACK
- BLACK/GRAY







SERIES: Basics, Synergy

SITE PLAN

DRAWN BY: Kari Champeau

Waterloo Firemen's Upper Park

500 Park Ave

Waterloo, WI 53594

Lee Recreation, LLC

142-146560-1

October 29, 2021

ADA ACCESSIBILITY GUIDELINE (ADAAG CONFORMANCE)

NUMBER OF PLAY EVENTS:	14
NUMBER OF ELEVATED PLAY EVENTS:	7
NUMBER OF ELEVATED PLAY EVENTS ACCESSIBLE BY RAMP:	PROVIDED: 0
NUMBER OF ELEVATED PLAY EVENTS ACCESSIBLE BY TRANSFER SYSTEM:	PROVIDED: 7
NUMBER OF ELEVATED PLAY EVENTS ACCESSIBLE BY RAMP OR TRANSFER SYSTEM:	PROVIDED: 7
NUMBER OF GROUND LEVEL PLAY EVENTS:	PROVIDED: 7
NUMBER OF TYPES OF GROUND LEVEL PLAY EVENTS:	PROVIDED: 2
RECD: 0	RECD: 0
RECD: 4	RECD: 4
RECD: 2	RECD: 2

WARNING!

ACCESSIBLE SAFETY SURFACING MATERIAL IS REQUIRED BENEATH AND AROUND THIS EQUIPMENT.  
FOR SLIDE FALL ZONE SURFACING AREA SEE CPSC's Handbook for Public Playground Safety.  
PLATFORM HEIGHTS ARE IN INCHES ABOVE RESILIENT MATERIAL.

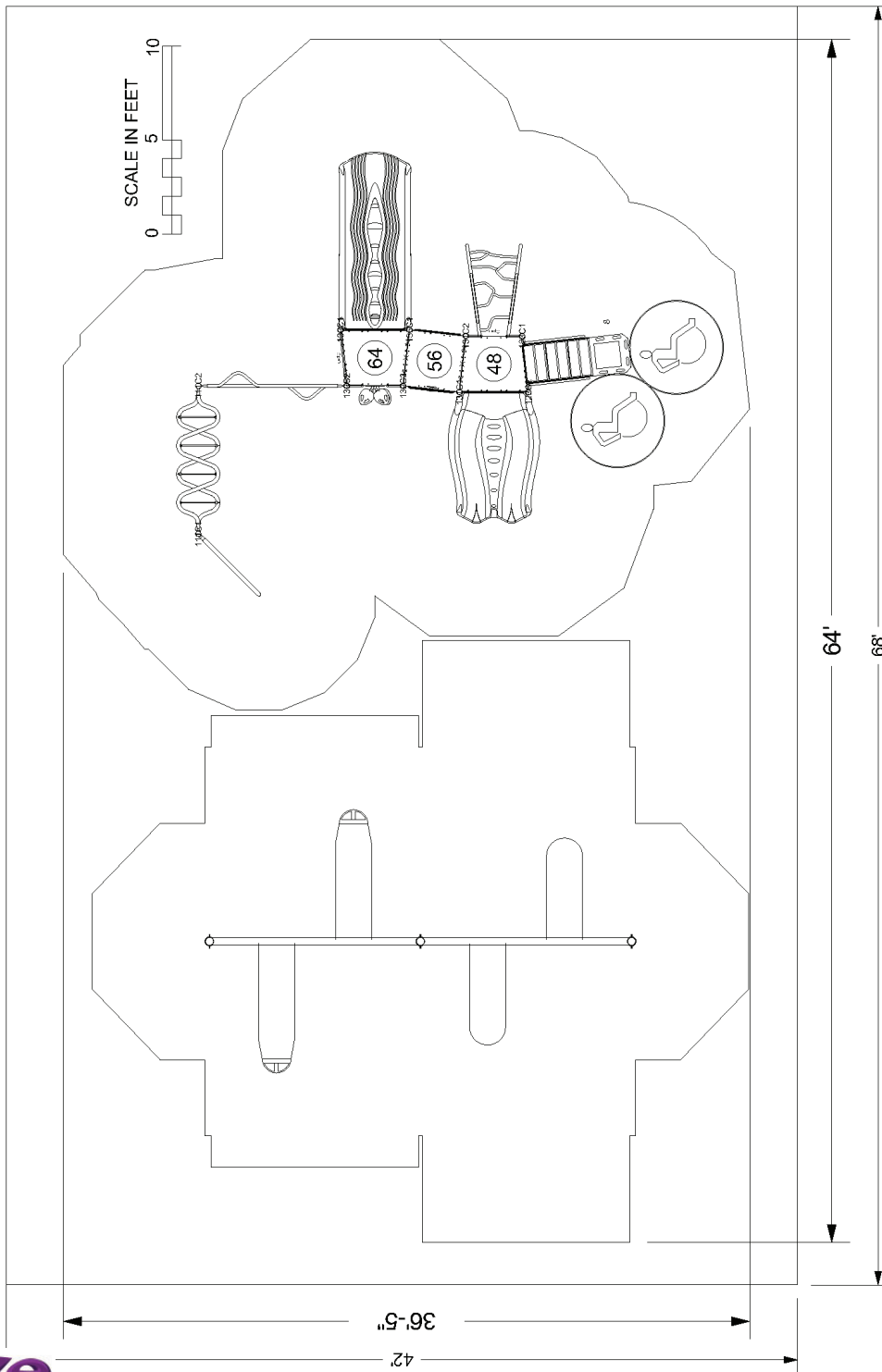

INFORMATION  
MINIMUM FALL ZONE  
SURFACED WITH  
RESILIENT MATERIAL  
AREA

1642 SQ.FT.

PERIMETER

253 FT.

STRUCTURE SIZE

36' 5" x 64' 0"

STRUCTURE IS DESIGNED  
FOR CHILDREN AGES:

- 6-23 MONTH OLDS
- 2-5 YEAR OLDS
- 5-12 YEAR OLDS
- 13 + YEAR OLDS



Registered  
to ISO 9001

Registered  
to ISO 14001



To verify product certification,  
visit [www.ipema.org](http://www.ipema.org)

The play components identified  
in this plan are IPEMA  
certified. The use and layout of  
these components conform to the  
requirements of ASTM F1487.  
To verify product certification,  
visit [www.ipema.org](http://www.ipema.org)

The space requirements shown  
here are to ASTM standards.  
Requirements for other standards  
may be different.

The use and layout of play  
components identified in this plan  
conform to the CPSC guidelines.  
U.S. CPSC recommends the  
separation of age groups in  
playground layouts.



Office (800) 775-8937  
 Fax (608) 423-7655

260 W. Main Street  
 Cambridge, WI 53523

info@leerecreation.com  
 www.leerecreation.com

## Quotation

DATE: Nov. 3, 2021

TO: Gabe Haberkorn  
 Village of Waterloo  
 136 N. Monroe St.  
 Waterloo, WI 53594

FROM: Jeff Thompson

RE: Playground Proposal #142-146560-1  
**Waterloo Fireman's Park – Upper Playground**

### BURKE "Play That Moves You"

Proposal #142-146560-1

14 Play Events for an Estimated 56 users – ages 2-12 years

Minimum area needed: 40' x 64'

1-Synergy Modular Playstructure Includes: \$22,961.00

**DECKS:** 1-Square, 2-Trapezoid

**CLIMBERS:** Transfer Station with Lil Novo Bean Step, Tree Branch Climber,  
 Leaf Climber, Apex Hole Climber, Power Pipes Climber, Beta  
 Climber

**SLIDES:** Luge Double Slide @ 48" Deck Ht., Contour Double Slide @ 64" Deck Ht.

**BALANCE:** Twisting Traverse

**PLAY ACTIVITY PANEL:** Collision Panel, Maze Panel

1-#SWING Single Post Swing Assembly \$ 2,937.00  
 Includes: 2 Swing Bays with 2 Belt Seats & 2 Infant/Tot Seats

Subtotal Equipment	\$25,898.00
Project Discount	(\$3,000.00)
Assembly/Installation	\$ 6,500.00
52 – 4' Border Timbers	\$ 2,080.00
Freight	<u>\$ 500.00</u>
<b>TOTAL</b>	<b>\$31,978.00</b>

Quote accepted by: \_\_\_\_\_ Date: \_\_\_\_\_

- TERMS: Net 20
- Site Preparation, Surfacing & Placement of Surfacing & Site Restoration is the responsibility of the Customer
- Lead-Time: 8-10 weeks upon receipt of order
- Quote effective: **Good through 11-30-2021**





COLOR KEY	
○	SILVER
●	GOLD
■	GRANITE
■	BURGUNDY
■	GRAY
■	GRAY/BLACK





**INFORMATION**  
 MINIMUM FALL ZONE  
 SURFACED WITH  
 RESILIENT MATERIAL  
 AREA  
 608 SQ.FT.  
 PERIMETER  
 98 FT.  
 STRUCTURE SIZE  
 32' 3" x 28' 2"

STRUCTURE IS DESIGNED  
 FOR CHILDREN AGES:

6-23 MONTH OLDS  
 2-5 YEAR OLDS  
 5-12 YEAR OLDS  
 13 + YEAR OLDS



The play components identified in this plan are IPEMA certified. The use and layout of these components conform to the requirements of ASTM F1487. To verify product certification, visit [www.ipema.org](http://www.ipema.org)

The space requirements shown here are to ASTM standards. Requirements for other standards may be different.

The use and layout of play components identified in this plan conform to the CPSC guidelines. U.S. CPSC recommends the separation of age groups in playground layouts.

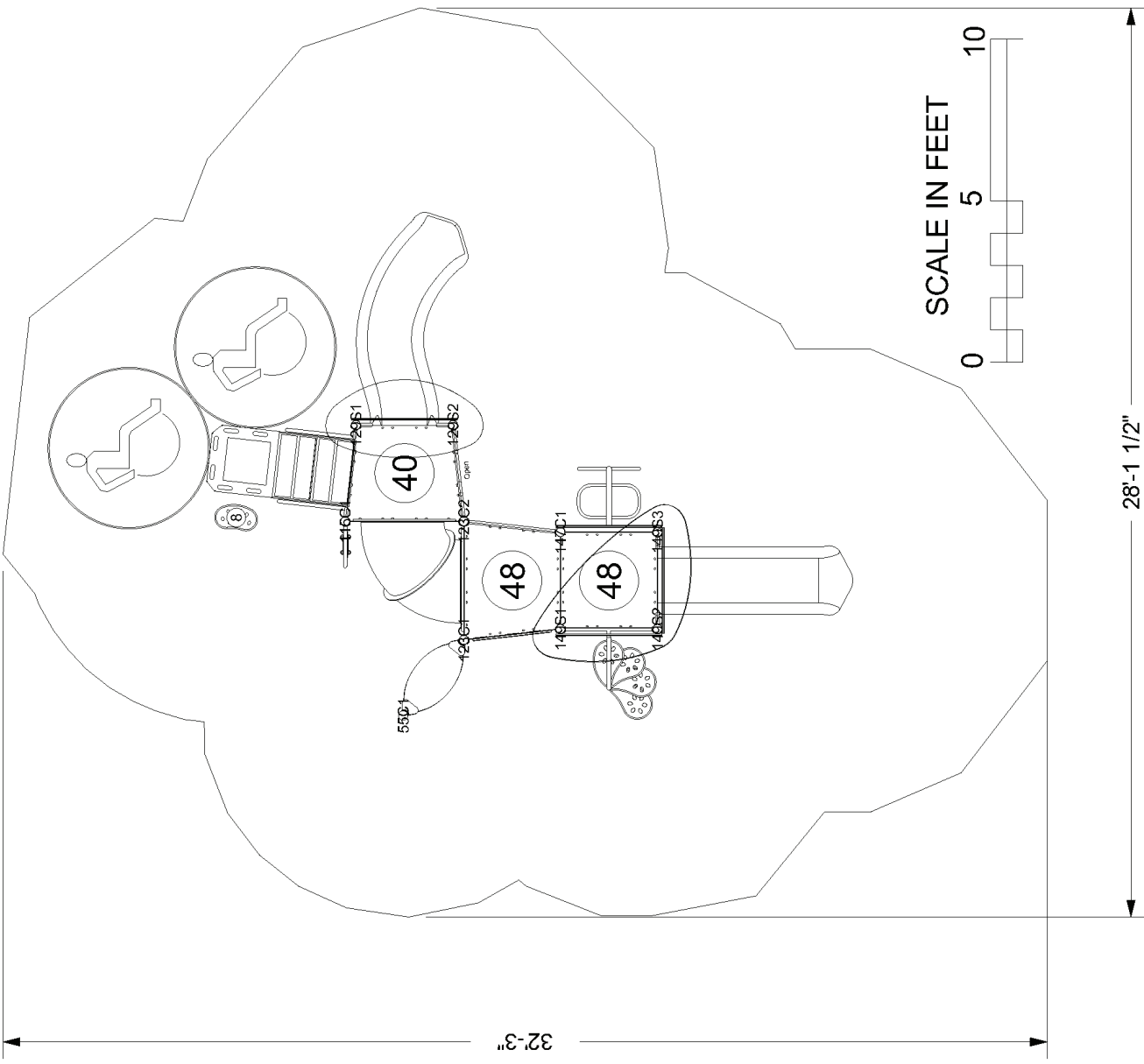

**ADA ACCESSIBILITY GUIDELINE (ADAAG CONFORMANCE)**

NUMBER OF PLAY EVENTS:	9
NUMBER OF ELEVATED PLAY EVENTS:	7
NUMBER OF ELEVATED PLAY EVENTS ACCESSIBLE BY RAMP:	PROVIDED: 0
NUMBER OF ELEVATED PLAY EVENTS ACCESSIBLE BY TRANSFER SYSTEM:	PROVIDED: 7
NUMBER OF ELEVATED PLAY EVENTS ACCESSIBLE BY RAMP OR TRANSFER SYSTEM:	PROVIDED: 4
NUMBER OF GROUND LEVEL PLAY EVENTS:	RECD: 2
NUMBER OF TYPES OF GROUND LEVEL PLAY EVENTS:	RECD: 2

**WARNING!**

ACCESSIBLE SAFETY SURFACING MATERIAL IS REQUIRED BENEATH AND AROUND THIS EQUIPMENT.  
 FOR SLIDE FALL ZONE SURFACING AREA SEE CPSC's Handbook for Public Playground Safety.  
 PLATFORM HEIGHTS ARE IN INCHES ABOVE RESILIENT MATERIAL.



October 29, 2021

SERIES: Synergy  
 SITE PLAN  
 DRAWN BY: Kari Champeau

Waterloo Regional Trailhead  
 760 McKay Way  
 Waterloo, WI 53594

Lee Recreation, LLC  
 142-146557-1



Office (800) 775-8937  
 Fax (608) 423-7655

260 W. Main Street  
 Cambridge, WI 53523

info@leerecreation.com  
 www.leerecreation.com

## Quotation

DATE: Nov. 3, 2021

TO: Gabe Haberkorn  
 Village of Waterloo  
 136 N. Monroe St.  
 Waterloo, WI 53594

FROM: Jeff Thompson

RE: Playground Proposal #142-146557-1  
**Waterloo Regional Trailhead**

### BURKE "Play That Moves You"

Proposal #142-146557-1

9 Play Events for an Estimated 34 users – ages 2-5 years  
 Minimum area needed: 36' x 32'

1-Synergy Modular Playstructure Includes: \$20,145.00

**DECKS:** 1-Square, 2-Trapezoid

**CLIMBERS:** Transfer Station with Lil Novo Bean Step, Tree Branch Climber,  
 Centipede Climber, Petal Step Climber

**SLIDES:** Rock 'n Roll Slide @ 48" Deck Ht., Monaco Curved Slide @ 40" Deck Ht.

**TUNNEL:** 90-Degree Tunnel between 2 decks

**PLAY ACTIVITY PANEL:** Hammock Seat, Acorn Panel, Rain Crescent Panel

**ROOFS:** 2-Elation Roofs

Subtotal Equipment	\$20,145.00
Project Discount	(\$2,500.00)
Assembly/Installation	\$ 5,000.00
34 – 4' Border Timbers	\$ 1,360.00
Freight	\$ 500.00
<b>TOTAL</b>	<b>\$24,505.00</b>

Quote accepted by: \_\_\_\_\_ Date: \_\_\_\_\_

- TERMS: Net 20
- Site Preparation, Surfacing & Placement of Surfacing & Site Restoration is the responsibility of the Customer
- Lead-Time: 8-10 weeks upon receipt of order
- Quote effective: **Good through 11-30-2021**









**RESOLUTION #2021-49**

**A RESOLUTION AMENDING THE 2021 BUDGET (Amendment #2)**

WHEREAS, the City of Waterloo has levied taxes and appropriated monies for expenditures for City operations in 2021, and

WHEREAS, unforeseen circumstances and events occurred in 2021, previously unanticipated when the budget was originally adopted,

NOW, THEREFORE BE IT RESOLVED, by the Common Council of the City of Waterloo that the 2021 budget be amended as follows:

**AMENDMENT DUE TO INCREASE/DECREASE IN REVENUE/EXPENSE**

		<b>ORIGINAL 2021 BUDGET</b>	<b>ADJUSTMENT</b>	<b>AMENDED 2021 BUDGET</b>
<b>FUND 600 Community Development Authority</b>				
<b>REVENUE</b>				
600-49-4930-000	Funds Applied To Budget	\$0.00	\$14,000.00	\$14,000.00
	<b>TOTALS</b>	<b>\$0.00</b>	<b>\$14,000.00</b>	<b>\$14,000.00</b>
<b>FUND 600 Community Development Authority</b>				
<b>EXPENSES</b>				
600-56-5670-210	Project Consulting Fees (Econ. Dev. Services)	\$0.00	\$14,000.00	\$14,000.00
	<b>TOTALS</b>	<b>\$0.00</b>	<b>\$14,000.00</b>	<b>\$14,000.00</b>
<b>FUND 400 Capital</b>				
<b>REVENUES</b>				
400-43-4372-000	Grant/Aid (Lead Water Service Aid)	\$0.00	\$100,000.00	\$100,000.00
400-43-4380-000	ARPA Funds	\$0.00	\$33,391.20	\$33,391.20
400-48-4831-000	Sale of Property Law Enforcement	\$0.00	\$8,741.00	\$8,741.00
	<b>TOTALS</b>	<b>\$0.00</b>	<b>\$142,132.20</b>	<b>\$142,132.20</b>
<b>FUND 400 Capital</b>				
<b>EXPENSES</b>				
400-51-5130-211	Attorney Fees	\$0.00	\$2,884.00	\$2,884.00
400-53-5310-215	Eng & Admin Prof Fees	\$68,494.00	\$70,316.83	\$138,810.83
400-53-5370-001	Lead Service Replace Program	\$0.00	\$100,000.00	\$100,000.00
400-57-5701-817	Capitol Proj Squad Car	\$0.00	\$41,958.22	\$41,958.22
	<b>TOTALS</b>	<b>\$0.00</b>	<b>\$141,958.22</b>	<b>\$283,653.05</b>
<b>FUND 225 Parks</b>				
<b>REVENUES</b>				
225-48-4852-000	Donations Firemen's Park (Trustees)	\$0.00	\$8,000.00	\$8,000.00
225-48-4851-000	Grants - Private (Watertown Comm. Foundation)	\$0.00	\$100,000.00	\$100,000.00
	<b>TOTALS</b>	<b>\$0.00</b>	<b>\$108,000.00</b>	<b>\$108,000.00</b>
<b>FUND 225 Parks</b>				
<b>EXPENSES</b>				
225-57-5701/000	Capital Project (playground purchased added)	\$164,000.00	\$28,164.27	\$192,164.27
	<b>TOTALS</b>	<b>\$164,000.00</b>	<b>\$28,164.27</b>	<b>\$192,164.27</b>

<b>FUND 200 FIRE/EMS</b>				
<b>REVENUES</b>				
220-43-4380-000	ARPA Funds	\$0.00	\$141,038.95	\$141,038.95
	<b>TOTALS</b>	<b>\$0.00</b>	<b>\$141,038.95</b>	<b>\$141,038.95</b>
<b>FUND 200 FIRE/EMS</b>				
<b>EXPENSES</b>				
220-59-5920-001	Debt Service Fund	\$0.00	\$141,038.95	\$141,038.95
	<b>TOTALS</b>	<b>\$0.00</b>	<b>\$141,038.95</b>	<b>\$141,038.95</b>

**ADOPTED** at a regular meeting of the Common Council on 12/16/2021

\_\_\_\_\_  
 Jenifer Quimby  
 Mayor

\_\_\_\_\_  
 Mo Hansen  
 Ciy Clerk/Treasurer

# Property Owner Request For Public Sidewalk Closure During Winter Months 970 Industrial Lane



Last Owner Name	SCHOENHERR
First Name Owner	SCOTT
Middle Initial	A
JrSr Owner	
Document Number	1207996
House Number Prefix	
House Number	970
House Number Suffix	
Street Direction	
Street Name	INDUSTRIAL LN
Apt/Unit	
City	WATERLOO
<a href="#">Zoom to</a>	

